

GS1

Soil Moisture Sensor

Operator's Manual

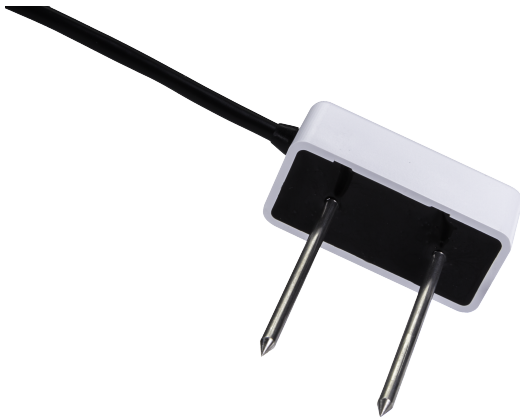

Decagon Devices, Inc.

Version: December 4, 2014 — 09:42:39

Decagon Devices, Inc.

2365 NE Hopkins Court
Pullman WA 99163

Phone: 509-332-5600

Fax: 509-332-5158

Website: www.decagon.com

Email: support@decagon.com or sales@decagon.com

Trademarks

“ECH2O” is a registered trademark of Decagon Devices, Inc.

©2001-2014 Decagon Devices, Inc.

All Rights Reserved

Contents

1	Introduction	1
1.1	Warranty	1
1.2	Seller's Liability	2
2	About GS1	3
2.1	Background	3
2.2	Specifications	3
3	Theory	5
3.1	Volumetric Water Content	5
3.2	Procedure	5
3.3	Orientation	6
3.4	Removing the Sensor	6
4	Connecting Sensors	7
4.1	Wiring	8
4.2	Sample Program	10
5	Calibration	13
5.1	Sensor Calibration Values	13
6	Maintenance and Troubleshooting	16
7	Declaration of Conformity	18

1 Introduction

Thank you for choosing Decagon's GS1 Volumetric Water Content sensor. This manual can help you understand the sensor features and ensure successful sensor operation. We hope you find the contents of this manual useful in understanding your instrument and maximizing its benefit to you.

There are several ways to contact Decagon if you ever need assistance with your product, have any questions, or feedback. Decagon has Customer Service Representatives available to speak with you Monday through Friday, between 8am and 5pm Pacific time.

Note: If you purchased your sensor through a distributor, please contact them for assistance.

Email:

support@decagon.com or **sales@decagon.com**

Phone:

509-332-5600

Fax:

509-332-5158

If contacting us by email or fax, please include as part of your message your instrument serial number, your name, address, phone, fax number, and a description of your problem or question.

Please read these instructions before operating your sensor to ensure that it performs to its full potential.

1.1 Warranty

The sensor has a 30-day satisfaction guarantee and a one-year warranty on parts and labor. Your warranty automatically validates upon receipt of the instrument.

1.2 Seller's Liability

Seller warrants new equipment of its own manufacture against defective workmanship and materials for a period of one year from the date of receipt of equipment.

Note: We do not consider the results of ordinary wear and tear, neglect, misuse, accident as defects.

The Seller's liability for defective parts shall in no event exceed the furnishing of replacement parts "freight on board" the factory where originally manufactured. Material and equipment covered hereby which is not manufactured by Seller shall be covered only by the warranty of its manufacturer. Seller shall not be liable to Buyer for loss, damage or injuries to persons (including death), or to property or things of whatsoever kind (including, but not without limitation, loss of anticipated profits), occasioned by or arising out of the installation, operation, use, misuse, nonuse, repair, or replacement of said material and equipment, or out of the use of any method or process for which the same may be employed. The use of this equipment constitutes Buyer's acceptance of the terms set forth in this warranty. There are no understandings, representations, or warranties of any kind, express, implied, statutory or otherwise (including, but without limitation, the implied warranties of merchantability and fitness for a particular purpose), not expressly set forth herein.

2 About GS1

The GS1 determines volumetric water content (VWC) by measuring the dielectric constant of the medium using capacitance and frequency domain technology. The 70 MHz frequency minimizes salinity and textural effects, making the GS1 accurate in almost any soil or soilless medium. It arrives with generic calibrations for mineral soils and soilless media included in this Operator's Manual.

The two-prong design and high measurement frequency allows the GS1 to measure VWC from 0 to 100% (VWC of saturated soils is generally 40 to 60% depending on the soil type) and allows accurate measurement of all soils and soilless medias with a wide range of salinities.

2.1 Background

In 2012, Decagon released our first stainless steel needle sensor, the GS3. The GS3 measures volumetric water content, temperature, and electrical conductivity. The sensor has a side-entry cable, which made it extremely easy to install in a trench application.

At the time, the GS3 was Decagon's highest priced water content sensor. However, its rugged design made it one of our most popular sensors. Our goal in developing the GS1 is to provide customers with a low-cost sensor that has the durability of the GS3.

2.2 Specifications

Measurement Time: 10 ms (milliseconds)

Accuracy: $\pm 0.03 \text{ m}^3/\text{m}^3$ in typical soils, up to 8 dS/m saturation extract EC.

With soil-specific calibration: ± 0.01 to $0.02 \text{ m}^3/\text{m}^3$ in any material.

Resolution: $0.001 \text{ m}^3/\text{m}^3$ VWC in mineral soils

Power Requirements: 3.0 VDC to 15 VDC (absolute maximum) @
15 mA

Output: 1,000 to 2,500 mV

Operating Environment: -40 to 50 °C¹

Range of Measurement: 0 to 100% VWC

Sensor dimensions: 8.9 cm x 1.8 cm x 0.7 cm

Connector Types: 3.5 mm (stereo) plug or stripped & tinned lead
wires (Pigtail)

Cable Length: 5 m standard; custom cable length available upon
request

Data logger Compatibility (not exclusive):

- Decagon: Em50, Em50R, Em50G, Em5b, and ProCheck
- Campbell Scientific: CR10X, CR850, 1000, 3000, etc.

¹Sensors can be used at higher temperatures under certain conditions. Please contact Decagon for assistance.

3 Theory

3.1 Volumetric Water Content

The GS1 sensor uses an electromagnetic field to measure the dielectric permittivity of the surrounding medium. The sensor supplies a 70 MHz oscillating wave to the sensor prongs that charges according to the dielectric of the material. The stored charge is proportional to substrate dielectric and substrate volumetric water content. The GS1 measures the charge and outputs a raw value that strongly correlates to VWC. Decagon has a few helpful reminders to consider before using your sensor.

- If you are installing sensors in a lightning prone area with a grounded data logger, please see our Application Note at www.decagon.com/lightning.
- Decagon advises that you test the sensors with your data logging device and software before going to the field.

Before you select a site for installation, remember that the soil next to the sensor surface has the strongest influence on its readings. It is important to avoid air gaps or extremely compact soil around the sensor, which can skew readings. Do not install the GS1 next to large metal objects, which can attenuate the sensor electromagnetic field and distort output readings.

Because the sensors have gaps between their prongs, it is also important to consider the size of the media where you insert the sensor. It is possible to get sticks, bark, roots or other material stuck between the sensor prongs, which will adversely affect readings. Finally, be careful when inserting the sensors into dense soil, as the prongs can bend if you apply excessive force when pushing them into the soil.

3.2 Procedure

Excavate a hole or trench a few centimeters deeper than the sensor installation depth. At the installation depth, shave off some soil from the vertical soil face to expos undisturbed soil. Insert the sensor into

the undisturbed soil face until both needles are pushed completely in the soil face so that the cable is coming towards the soil surface with no bends. The tip of each prong has been sharpened to make it easier to push in the sensor. Be careful to avoid the sharp tips. Back fill the trench taking care to pack the soil back to natural bulk density around the white PVC portion of the sensor.

3.3 Orientation

You may orient the GS1 in any direction. However, to eliminate cable strain, orient the sensor vertically so that the cable exit is closest to the soil surface, and does not need to bend.

3.4 Removing the Sensor

When removing the sensor from the soil, do not pull it out of the soil by the cable! Doing so may break the internal connections and make the sensor unusable. Instead, dig down to where the sensor is located and uninstall horizontally.

4 Connecting Sensors

Decagon designed the GS1 sensor for use with our Em50 series data loggers, the Em5b, or the ProCheck handheld reader. The standard sensor (with a 3.5 mm “stereo plug” connector) quickly connects to and is easily configured within a Decagon logger or ProCheck. (Figure 1)



Figure 1: Stereo Connector

The GS1 sensor incorporates several features that also make it an excellent sensor for use with third party loggers. Customers may purchase the sensor with stripped and tinned wires (pigtail) for terminal connections.

The GS1 sensor comes standard with a five meter cable. Customers may purchase sensors with custom cable lengths for an additional fee (on a per-foot fee basis). Obtaining custom length cables eliminates the need for splicing the cable (a possible failure point).

Connecting to an Em50/Em50R Logger

Decagon designed the GS1 to work specifically with the Em50 and Em5b data loggers. Simply plug the 3.5 mm stereo plug connector directly into one of the five sensor ports. Next, configure the logger port for the GS1 and set the measurement interval.

Connecting to ECH2O Utility

Configure your Decagon data loggers using either ECH2O Utility

or DataTrac 3. Before trying to configure your logger, please check your software version to ensure it will support the GS1. To update your software to the latest version, please visit Decagon's software download site at www.decagon.com/support.

The following software support the GS1 sensor:

- ECH2O Utility 1.12 or greater
- ECH2O DataTrac 3 or greater

Note: You must use the ECH2O Utility, DataTrac 3 or a terminal program on your computer to download data from the logger to your computer.

4.1 Wiring

Connecting to a non-Decagon Logger

Customers may purchase GS1 sensors for use with non-Decagon data loggers. These sensors typically come configured with stripped and tinned (pigtail) lead wires for use with screw terminals. Refer to your distinct logger manual for details on wiring.



Figure 2: Pigtail End Wiring

Pigtail End Wiring

Connect the wires to the data logger as Figure 3 shows, with the supply wire (white) connected to the excitation, the analog out wire (red) to a analog input, the bare ground wire to ground as illustrated in Figure 3.

Note: The acceptable range of excitation voltages is from 3.6 to 15 VDC. If you wish to read your Decagon sensor with the Campbell Scientific Data Loggers, you will need to power the sensors off of the switched 12 V port.

If your GS1 is equipped with the standard 3.5 mm plug and you want to connect it to a non-Decagon data logger, you have two options. First, you can clip off the plug on the sensor cable, strip and tin the wires, and wire it directly into the data logger. This has the advantage of creating a direct connection with no chance of the sensor becoming unplugged; however, it cannot be easily used in the future with a Decagon readout unit or data logger.

The other option is to obtain an adapter cable from Decagon. The 3-wire sensor adapter cable has a connector for the sensor jack on one end, and three wires on the other end for connection to a data logger (this type of wire is often referred to as a “pigtail adapter”). Both the stripped and tinned adapter cable wires have the same termination as seen above; the white wire is excitation, red is output, and the bare wire is ground.

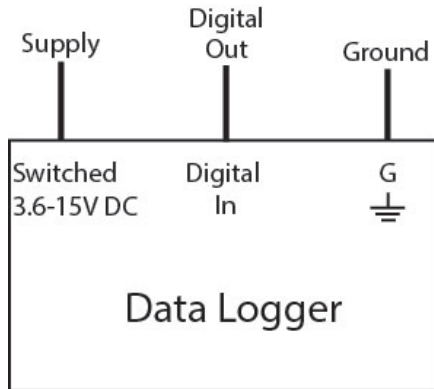

Figure 3: Wiring Diagram

Note: The acceptable range of excitation voltages is from 3.6 to 15 VDC. If you wish to read the sensor with the Campbell Scientific Data Loggers, you must power the sensors off a 12 V or switched 12

V port.

4.2 Sample Program

The following programs are examples that can be used with data Campbell Scientific data loggers. The first program is for CR3000 data logger, but can easily be adapted for other “CRBasic” type loggers. The second program is for a CR10X data logger, but can be easily adapted to other “Edlog” type loggers. The GS1 needs 3.6 to 15 V DC excitation and therefore cannot be excited with the 2.5 V excitation port of many Campbell Scientific data loggers. We recommend using the switched 12 V or CAO port to excite the GS1.

CR Basic Type Data Logger

```
'CR3000 Series Datalogger
'date: 7/7/2014
'program author: Kahlin Wacker
'program to read one Decagon GS1 sensor
' right click on commands for more info.
'wiring
'white - SW - 12 1
'red - SE CH1
'bare gnd

Public GSonemV, VWC 'variables
DataTable (Table1,1,-1) ' the data table logs every 60 minutes
DataInterval (0,60,Min,10)
Average (1,VWC,FP2,False)
EndTable

BeginProg
Scan(10,Sec,0,0) ' interval between program runs
SW12(1,1)' turn on the 12 volt power to the sensor
VoltSe (GSonemV,1,mV5000,21,1,10000,_60Hz,1.0,0)
'read the voltage from the sensor
SW12 (1,0) ' turn off the 12 volt power to the sensor
```

```

VWC = 0.000494 * GSonemV - 0.554 'mineral soil calibration
CallTable Table1 ' write data to data table
NextScan
Endprog

```

Edlog Type Data Logger

```

;{CR10X}
;
;program to read GS1 sensor with CR10X
;
;wiring:
;Jumper from C1 to SW 12V CTRL - C1
;is used to turn on the switched 12V port
;GS1 white - excitation - SW 12V
;GS1 red - Vout - SE CH1
;GS1 bare - gnd - G or AG

*Table 1 Program
 01: 10.0000 Execution Interval (seconds)

;set C1 high to pull SW 12 port high
;

1: Do (P86)
  1: 41 Set Port 1 High

2: Excite-Delay (SE) (P4)
  1: 1 Reps
  2: 5 2500 mV Slow Range
  3: 1 SE Channel
  4: 1 Excite all reps w/Exchan 1
  5: 1 Delay (0.01 sec units)
  6: 0 mV Excitation
  7: 2 Loc [ VWC ]
  8: .000494 Multiplier
  9: -0.554 Offset

;turn off excitation

```

3: Do (P86)

1: 51 Set Port 1 Low

4: If time is (P92)

1: 0000 Minutes (Seconds --) into a

2: 60 Interval (same units as above)

3: 10 Set Output Flag High (Flag 0)

5: Real Time (P77)

1: 1110 Year,Day,Hour/Minute (midnight = 0000)

6: Average (P71)

1: 1 Reps

2: 2 Loc [VWC]

*Table 2 Program

02: 0.0000 Execution Interval (seconds)

*Table 3 Subroutines

End Program

5 Calibration

Decagon's ECH2O Utility and DataTrac3 automatically apply factory calibrations to the sensor output data. However, this general calibration may not be applicable for all soil types. For added accuracy we encourage our customers to perform soil-specific calibrations.

Which calibration equation you use depends on where you use it. If you use it with sensors connected to a non-Decagon data logger you will need to use the mV calibration. If you use any Decagon software (DataTrac3, ECH2O Utility, etc.) or the user calibration menu in the ProCheck, you must use the RAW calibration. The difference between the two is the slope constant. To increase the resolution of the sensor output, Decagon uses all available increments of the 12-bit number (value of 4096) where the measurement is stored.

5.1 Sensor Calibration Values

Following is a list of the both the millivolt and RAW calibration values for the GS1, where Θ is the volumetric water content, mV is the millivolt output of the sensor, and where RAW is the raw sensor output, when you read the sensor with a Decagon logger.

The GS1 is not sensitive to variation in texture and electrical conductivity because it runs at a high measurement frequency. Therefore, its general calibration equation should apply for most mineral soils up to 8 dS/m saturation extract. Its calibration equations are shown below for mineral soil and soilless growing media (potting soil, perlite, peat moss). However, for added accuracy we encourage our customers to perform soil-specific calibrations.

Mineral Soils

According to our tests, a single calibration equation will generally suffice for most mineral soil types with electrical conductivities from 0.1 dS/m to 8 dS/m saturation extract. Volumetric water content

Θ) is given by:

$$\Theta = 3.62 * 10^{-4} * RAW - 0.554 \quad (1)$$

where RAW is the output from the Decagon data logger. If you are using a non-Decagon data logger, VWC is given by:

$$\Theta = 4.94 * 10^{-4} * mV - 0.554 \quad (2)$$

where mV is the output of the sensor when excited with 3.6 to 15 V. Please note that the equation will reach a maximum at $\sim 60\%$ volumetric water content (VWC) in pure water. To display data on a scale from 0 to 100%, VWC should be modeled with a quadratic equation (which would result in a 100% VWC in water), but a linear equation fits the mineral soil VWC range as well as the quadratic, and linear equations are easier to deal with, especially since mineral soil typically saturates at ~ 40 to 50% VWC.

Soilless Growing Media

The GS1 has been calibrated in media types including potting soil, perlite and peat. The goal of these calibrations is to create a generic calibration equation that works in all types of each substrate, with an accuracy of better than $\pm 5\%$ volumetric water content (VWC). If you need more accuracy, you can perform a media specific calibration to get the accuracy down to ± 1 to 2%. It is interesting to note the main difference between the calibrations is caused by the high air volume in the organic soils that lowers the starting (dry media) output of the sensor. For more information on how to calibrate your probes, please see <http://www.decagon.com/support>. Decagon also has a calibration service, where we perform the calibration for a standard fee. Contact Decagon for more information about this calibration service.

The calibration for several potting soils, perlite, and peat moss at salinities ranging from 0 to > 4 dS/m is given:

$$\Theta = 4.33 * 10^{-4} * RAW - 0.611 \quad (3)$$

for a Decagon data logger or

$$\Theta = 5.91 * 10^{-4} * mV - 0.611 \quad (4)$$

for a data logger with 3.6 to 15 V excitation.

6 Maintenance and Troubleshooting

If you encounter problems with the GS1, they most likely will manifest themselves in the form of incorrect or erroneous readings. Before contacting Decagon about the sensor, do the following:

- Check to make sure the connections to the data logger are both correct and secure.
- Ensure that your data logger batteries are not dead or weakened.

If you continue to encounter problems, please contact Decagon at (509) 332-5600 or at support@decagon.com.

1. PROBLEM:

Sensor not responding.

SOLUTION:

- Check power to the sensors
- Check sensor cable and 3.5 mm plug integrity
- Check data logger wiring to ensure White - 12 V supply, Red - Analog In, Bare - Ground

2. PROBLEM

Sensor reading to low.

SOLUTION:

- Check for air gaps around sensor needles. These could be produced below the surface of the substrate when the needle contacts a large piece of material and pushes them out of the way.
- Ensure the calibration equation you use is appropriate for your media type. There are significant differences between substrate

calibrations so be sure to use the one specific to your substrate.

3. PROBLEM

Sensor readings are too high.

SOLUTION:

- Check to make sure that the soil was not packed excessively during sensor installation. Higher density can cause elevated sensor readings.
- Ensure the calibration equation you are using is appropriate for your media type. There are significant differences between substrate calibrations so be sure to use the one specific to your substrate.

7 Declaration of Conformity

Application of Council Directive:	2004/108/EC and 2011/65/EU
Standards to which conformity is declared:	EN 61326-1:2013 and EN 50581:2012
Manufacturer's Name:	Decagon Devices, Inc. 2365 NE Hopkins Ct. Pullman, WA 99163 USA
Type of Equipment:	Soil Moisture Sensor
Model Number:	GS1
Year of First Manufacture:	2014

This is to certify that the GS1 dielectric soil moisture sensor, manufactured by Decagon Devices, Inc., a corporation based in Pullman, Washington, USA meets or exceeds the standards for CE compliance as per the Council Directives noted above. All instruments are built at the factory at Decagon and pertinent testing documentation is freely available for verification.

Index

- Accuracy, 3
- Calibration
 - Mineral Soils, 13
 - Sensor, 13
 - Soilless Growing Media, 14
 - Values, 13
- CE Compliance, 18
- Connecting
 - ECH2O Utility, 7
 - Em50 Series Data Logger, 7
 - Em5b, 7
 - ProCheck, 7
- Contact Information, 1
- Customer Support, 1
- Data Logger
 - Compatibility, 4
- Declaration of Conformity, 18
- ECH2O Utility, 8
- Email, 1
- Extension Cables, 7
- Fax, 1
- Logger
 - Communications, 9
 - Connection, 9
 - Non-Decagon, 8
 - Sample Program, 10
- Phone, 1
- Plug Wiring, 19
- Power Requirements, 4, 9
- Seller's Liability, 2
- Specifications, 3
- Troubleshooting, 16
- Warranty, 1
- Wiring
 - Pigtail, 8
 - Stereo Plug, 8
- Wiring Diagrams, 8