



Accessories

FILTER CAPS FOR HUMIDITY AND DEWPOINT SENSORS WITH PROBE Ø12 mm (0.47")

The right choice of appropriate filter cap is essential for best long term performance in the application. For assistance please contact the E+E representative - www.epluse.com/en/service-support/locations-distributors/.



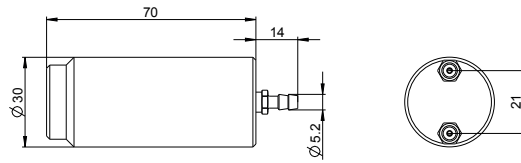

FILTER NAME	CONSTRUCTION	FEATURES	APPLICATIONS	ORDER CODE
Membrane 	Body: polycarbonate Filter: PTFE membrane Pores size: 1 µm Length: 34 mm (1.34")	<ul style="list-style-type: none"> • Very good protection against fine dust • T range: -40...80 °C (-40...176 °F) • Response time t10/90: 15 s 	<ul style="list-style-type: none"> • Building automation • Dusty environment 	HA010101 (light grey) HA010118 (black)
Stainless steel sintered 	Material: sintered stainless steel Pores size: 10 µm Length: 33 mm (1.30")	<ul style="list-style-type: none"> • For high mechanical stress and strong pollution • T range: -40...180 °C (-40...356 °F) • Response time t10/90: 30 s 	<ul style="list-style-type: none"> • Industrial process control • Agriculture • Life stock barns 	HA010103 (for plastic probes) HA010117 (for metal probes)
PTFE 	Material: PTFE sintered Pores size: 50 µm Length: 33 mm (1.30")	<ul style="list-style-type: none"> • For very dirty, oily environment • T range: -40...180 °C (-40...356 °F) • Response time t10/90: 14 s 	<ul style="list-style-type: none"> • Industrial process control • Chemical industry • Very polluted environment 	HA010105
Metal grid 	Body: polycarbonate Filter: stainless steel wire mesh Pores size: 30 µm Length: 33 mm (1.30")	<ul style="list-style-type: none"> • For high RH / condensing environment, • low mechanical stress and • low pollution level • T range: -40...120 °C (-40...248 °F) • Response time t10/90: 15 s 	<ul style="list-style-type: none"> • Climate control • Dryers and humidifiers • HVAC 	HA010106 (light grey) HA010119 (black)
Stainless steel grid 	Body: stainless steel Filter: stainless steel wire mesh Pores size: 30 µm Length: 39 mm (1.54")	<ul style="list-style-type: none"> • For high RH / condensing environment, • average mechanical stress and • low pollution level • T range: -40...180 °C (-40...356 °F) • Response time t10/90: 15 s 	<ul style="list-style-type: none"> • Industrial process control • Clean rooms 	HA010109
H₂O₂ 	Material: PTFE sintered Pores size: 50 µm Length: 33 mm (1.30")	<ul style="list-style-type: none"> • Catalytic filter for H₂O₂ environment • T range: -40...180 °C (-40...356 °F) • Response time t10/90: 14 s 	<ul style="list-style-type: none"> • Pharma • Biotech • Sterilization with H₂O₂ 	HA010115
PTFE stainless steel 	Body: stainless steel Filter: PTFE membrane, replaceable Pores size: 2 µm Length: 39 mm (1.54")	<ul style="list-style-type: none"> • For high RH / condensing environment, • high pollution levels • T range: -40...180 °C (-40...356 °F) • Response time t10/90: 14 s • Water ingress pressure > 0.5 bar 	For EE33-J and EE33-K in: <ul style="list-style-type: none"> • Meteorology, outdoor • Climate control 	HA010114 (complete filter) HA010114ME (PTFE membrane)
Metal grid for EE08 	Body: polycarbonate Filter: stainless steel wire mesh Pores size: 30 µm Length: 25 mm (1")	<ul style="list-style-type: none"> • For high RH / condensing environment, • low mechanical stress, • low pollution level • T range: -40...120 °C (-40...248 °F) • Response time t10/90: 15 s 	<ul style="list-style-type: none"> • Meteorology, outdoor • Climate control 	HA010113
Stainless steel 	Material: stainless steel Openings: ø3 mm Length: 32 mm (1.26")	<ul style="list-style-type: none"> • For moisture in oil measuring devices 	<ul style="list-style-type: none"> • Hydraulic, lubrication and isolation oil monitoring 	HA010110

FILTER CAPS FOR EE872 CO₂ PROBES Ø25 mm (0.98")









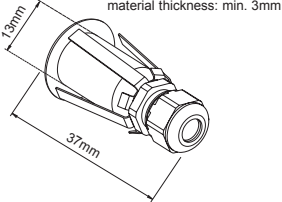

NAME	CONSTRUCTION	FEATURES	APPLICATIONS	ORDER CODE
PTFE 	Material: PTFE sintered Pores size: 50 µm Length: 62 mm (2.44")	<ul style="list-style-type: none"> Standard filter for CO₂ probes T range: -40...60 °C (-40...140 °F) 	<ul style="list-style-type: none"> Greenhouses Agriculture Outdoor CO₂ monitoring 	HA010123
H₂O₂ 	Material: PTFE sintered Pores size: 50 µm Length: 62 mm (2.44")	<ul style="list-style-type: none"> Catalytic filter for H₂O₂ environment T range: -40...60 °C (-40...140 °F) 	<ul style="list-style-type: none"> Pharma Biotech Sterilization with H₂O₂ 	HA010124
Calibration adapter / Protection cap 	Material: Polycarbonate	Dimensions in mm		HA010785

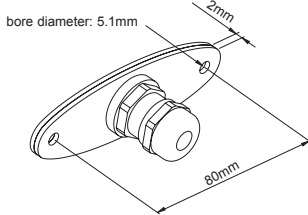

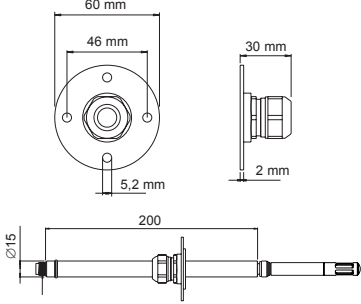
MOUNTING FLANGES

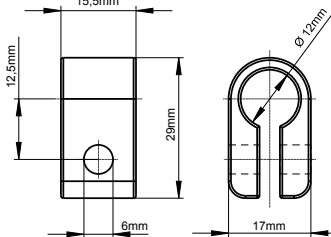
NAME	SUITABLE FOR	DIMENSIONS in mm	ORDER CODE
Plastic flange Ø12 mm (0.47") 	EE072 EE160 EE210 EE576 EE650 EE660 EE850 EE8915 EE060 EE061 EE671		HA010202 (light grey)
Plastic flange Ø6 mm (0.24") 	EE074 EE150 EE431		HA401101
Stainless steel flange Ø12 mm (0.47") 	EE072 EE074 EE23 EE33 EE310 EE1900 EE1950		HA010201
Stainless steel flange Ø25 mm (0.98") 	EE872		HA010226

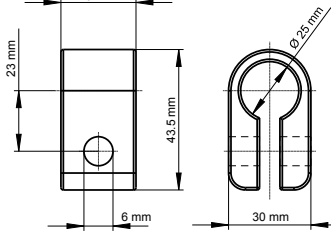
MOUNTING FLANGES

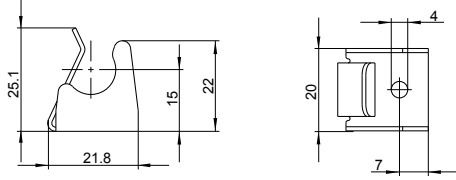
NAME	SUITABLE FOR	DIMENSIONS in mm	ORDER CODE
Stainless steel flange Ø5 mm (0.2") 	EE23 - model T6	 <p>bore diameter: 13 mm material thickness: min. 3mm</p>	HA010208
Stainless steel flange Ø8 mm (0.3") 	EE074 EE33-MFTJ (temperature probe) EE75	 <p>bore diameter: 5.1mm</p>	HA010207
Duct mounting kit 	EE07		HA010209
Wall mounting clip Ø12 mm (0.47") 	All probes Ø12 mm (0.47") T range: -40...60 °C (-40...140 °F) Material: LDPE		HA010211
Wall mounting clip Ø25 mm (0.98") 	EE872 T range: -40...60 °C (-40...140 °F) Material: LDPE		HA010227
Stainless steel wall mounting clip Ø12 mm (0.47") 	EE23 EE33 EE310 EE1900 EE1950	Material: stainless steel 1.4404 	HA010225

MOUNTING FLANGES

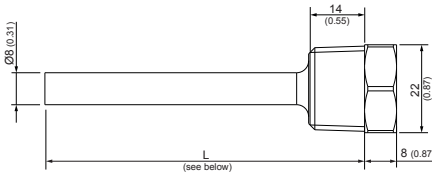
NAME	SUITABLE FOR	DIMENSIONS in mm	ORDER CODE
Immersion well	EE074		
	EE431		
	EE461		
	EE462		
	EE471		
		length (L)	R$\frac{1}{2}$" ISO $\frac{1}{2}$" NPT
		50 mm (1.97")	brass HA400101 HA400111 stainless steel HA400201 HA400211
		100 mm (3.94")	brass HA400104 HA400114 stainless steel HA400204 HA400214
		135 mm (1.97")	brass HA400102 HA400112 stainless steel HA400202 HA400212
		285 mm (11.22")	brass HA400103 HA400113 stainless steel HA400203 HA400213

LC DISPLAYS

NAME	SUITABLE FOR	ORDER CODE	
LC display + cover	EE23	metal D03M-EE23 polycarbonate D03P-EE23	
	EE23-T5	metal D05M-EE23T5 polycarbonate D05P-EE23T5	
	EE33	metal D05M-EE33	
	EE220	metal D07M-EE220 polycarbonate D07P-EE220	



POWER SUPPLY UNIT

NAME	SUITABLE FOR	DESCRIPTION	ORDER CODE
Power supply adapter	All E+E devices with 24 V DC supply max: 0.625 A	External power supply 100-240 V AC / 50-60 Hz 0.5 A Suitable for Europe / US / UK / Korea / China	V03



REPLACEMENT SENSING ELEMENTS

NAME	SUITABLE FOR	DESCRIPTION	ORDER CODE
Replacement sensing elements	EE23	Replacement humidity sensing elements	FE09
	EE310	Replacement temperature sensing elements	FE09-HC01 (with proprietary coating) TE38

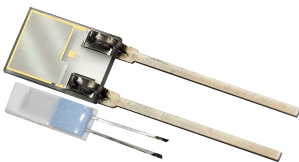

SAMPLING CELLS

NAME	SUITABLE FOR	DESCRIPTION	ORDER CODE
------	--------------	-------------	------------

Basic sampling cell

EE354
 EE355
 EE371

The basic sampling cell is designed for a pressure range from 0...64 bar (0...928 psi). It allows a simple integration of a dew point sensor into a self-constructed sampling system.

ISO: **HA050103**
 NPT: **HA050105**



Dimensions in mm:

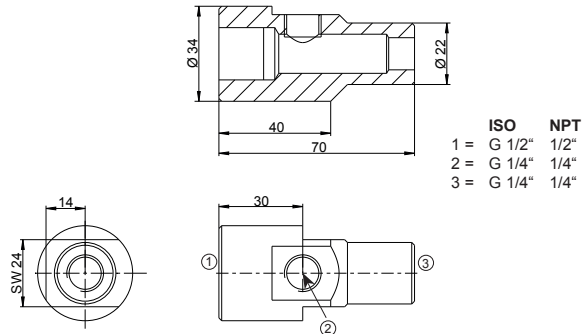

ISO sampling cell

EE354
 EE355
 EE371

The sampling cell is optimized for compressed air lines with pressure range 0...10 bar (0...145 psi). The flow of air can be adjusted with the bleed screw. The G 1/2" ISO version features a quick connector suitable for standard DN7.2 air connection, which allows for the sampling cell to be mounted and removed without process interruption.

ISO: **HA050102**



Dimensions for ISO (in mm):

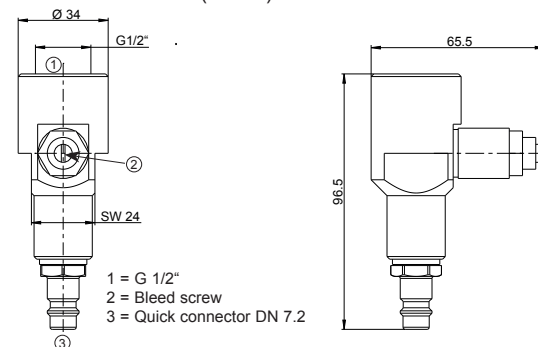

NPT sampling cell

Dimensions for NPT (in mm):

NPT: **HA050107**

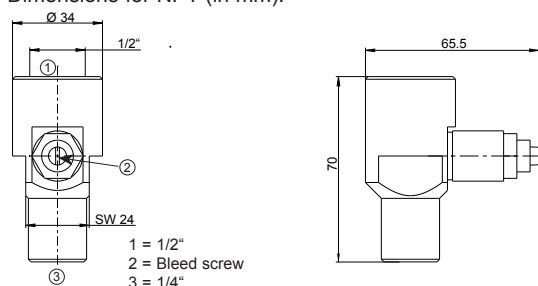

SAMPLING CELLS

NAME	SUITABLE FOR	DESCRIPTION	ORDER CODE
------	--------------	-------------	------------

Sampling cell for atmospheric dew point

EE354
EE355
EE371

The sampling cell is optimized for measuring the atmospheric dew point temperature in compressed air lines with pressure range 0...10 bar (0...145 psi). It features a quick connector suitable for standard DN7.2 air connection, which allows for the sampling cell to be mounted and removed without process interruption. The pressure in the sampling cell could be zeroed by the needle valve.

HA050106



Dimensions in mm:

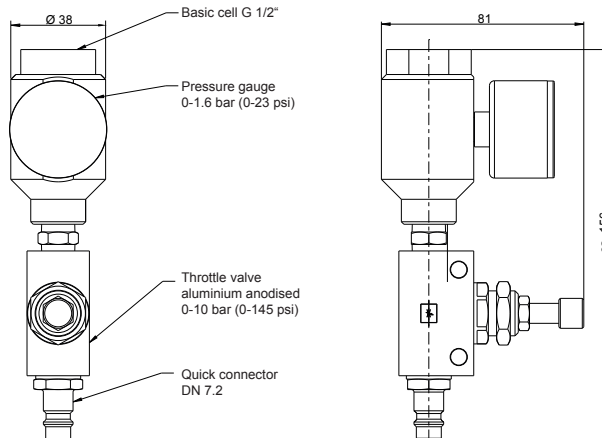

DRIP WATER PROTECTION

In applications with high humidity and condensation or for outdoor use, sensor probes should be protected against dripping water.

NAME	SUITABLE FOR	DESCRIPTION	ORDER CODE
------	--------------	-------------	------------

Drip water protection

All sensing probes with $\varnothing 12$ mm (0.47")

Protection cap $\varnothing 85$ mm (3.35"), fixing onto the sensing probe by cable gland.

HA010503



PROTECTION CAP

NAME	SUITABLE FOR	DESCRIPTION	ORDER CODE
------	--------------	-------------	------------

Protection cap for $\varnothing 12$ mm (0.47") probe

All sensing probes with $\varnothing 12$ mm (0.47")

Sensing head protection during site cleaning or sterilization.
T range: -40...80 °C (-40...176 °F)







HA010783

L: 50.4 mm (1.98")
 \varnothing : 12.5 mm (0.49")





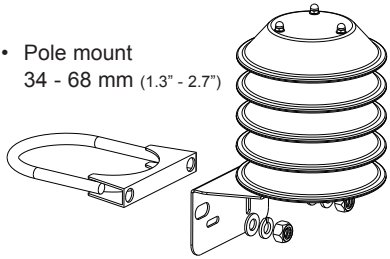

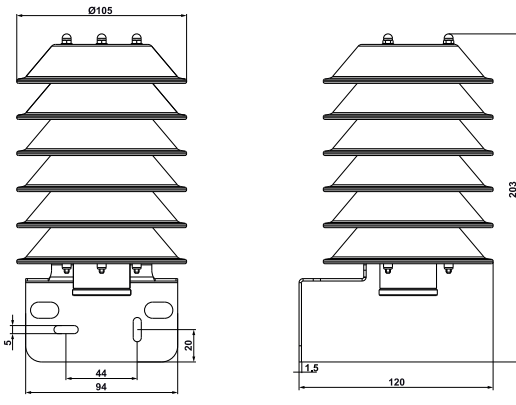

RADIATION SHIELD

For outdoor applications the measuring devices shall be equipped with a radiation shield which provides protection from rain, snow and ice. This causes also a natural ventilation which largely prevents overheating of the sensing probe in the sun and thus a distortion of the measured values. All E+E radiation shields are suitable for wall and pole mount.

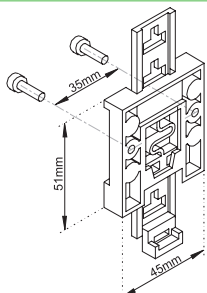
NAME	SUITABLE FOR	DESCRIPTION	ORDER CODE
 Radiation shield for EE210	EE210-Outdoor		HA010501
 Radiation shield with fixed clamping ring (M20x1.5) for probes with Ø12 mm (0.47")	EE07 EE08 type E EE060 EE061 EE072 EE33-J (RH probe) with remote sensing probe: EE23 EE310 EE210	 Ø105 174 44 94 20 Ø5 1.5 122	HA010502
 Radiation shield with screw-in thread (M16x1.5) and additional cable gland for probes with Ø6 mm (0.24")	EE08 type D EE33-J (T probe)	• Wall mount  • Pole mount 34 - 68 mm (1.3" - 2.7") 	HA010506
 Radiation shield for EE872	EE872	 Ø105 5 44 94 20 1.5 120 203	HA010510

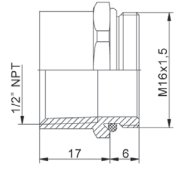
Wall mount and pole mount (see above)

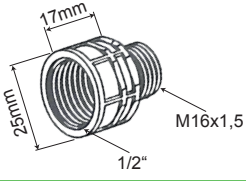
MOUNTING AND CONNECTING AIDS

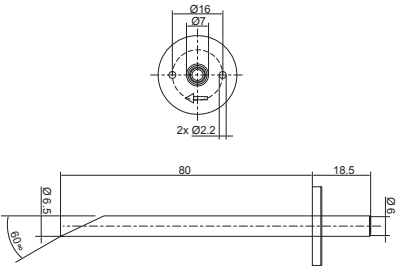
NAME	SUITABLE FOR	DIMENSIONS / DESCRIPTION	ORDER CODE
 <p>Bracket for DIN rail mounting</p>	EE23 EE220 EE310 EE360 Only for plastic enclosure.		HA010203
 <p>Conduit adapter, stainless steel</p>	Devices with cable gland M16x1.5	Adapter M16x1.5 to 1/2" NPT (US conduit fitting) 	HA011101
 <p>Conduit adapter, plastic</p>	Devices with cable gland M16x1.5	Adapter M16x1.5 to 1/2" NPT (US conduit fitting) 	HA011110
 <p>Pressure tight feedthrough</p>	EE33-MFTJx EE33-MFTKx	For probes with $\varnothing 12$ mm (0.47") and $\varnothing 6$ mm (0.24") Probe assembly up to 20 bar (300 psi)	HA011102: 1/2" ISO, probe: $\varnothing 12$ mm (0.47") HA011103: 1/2" NPT, probe: $\varnothing 12$ mm (0.47") HA011104: 1/2" ISO, probe: $\varnothing 6$ mm (0.24") HA011105: 1/2" NPT, probe: $\varnothing 6$ mm (0.24")
 <p>Pressure connection set</p>	EE600 EE610	2 m (78.7") PVC hose with two ABS pressure connection nipples 	HA011304



REFERENCE PROBES

NAME	SUITABLE FOR	DESCRIPTION	ORDER CODE
 <p>Reference probe</p>	EE220	EE07 probes with fix output values for checking the EE220 basic unit (test report included). probe 1: 90 % RH / 5 °C (41 °F) probe 2: 10 % RH / 45 °C (113 °F)	HA010403



INTERFACE CABLES AND CONVERTORS

NAME	SUITABLE FOR	DESCRIPTION	ORDER CODE
RS232 to USB 	E+E devices with RS232 interface	High speed converter from RS232 DB9 (male) to USB Microsoft WHQL approved	HA020110
E2 to RS232 for EE07 	EE07	E2 to RS232 converter, incl. software for test and data Connector A: M12 Connector B: DB9 (female) Cable length: 2 m (6.6 ft)	HA011001
E2 to RS232 for EE03 	EE03	E2 to RS232, incl. software for test and data recording Connector A: 4 pole wire to board connector Connector B: DB9 (female) Cable length: 2 m (6.6 ft)	HA011002
E2 Test and configuration adapter 	EE894 with E2 interface	Connecting CO ₂ modules with E2 interface to a PC for test and configuration, incl. software and supply adapter. Connector A: Test board with power supply Connector B: DB9 (female)	HA011010
E2 to RS232 for EE08 	EE08	E2 to RS232, incl. software for configuration, adjustment or test Connector A: screw terminal or M12 via connection cable Connector B: DB9 (female) Cable length: 2 m (6.6 ft)	HA011005
RS232 interface cable with free ends 	EE33	RS232 interface cable for connection to screw terminals Connector A: DB9 (female) Connector B: flying leads Cable length: 2 m (6.6ft)	HA010301
RS232 interface cable 	EE33 EE371 EE381	RS232 interface cable Connector A: DB9 (female) Connector B: 6 pol wire to board connector Cable length: 2 m (6.6 ft)	HA010304
RS232 interface 	EE33	RS232 interface cable with connector option C06 Connector A: DB9 (female) Connector B: M12 Cable length: 2 m (6.6 ft)	HA010311



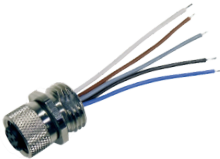
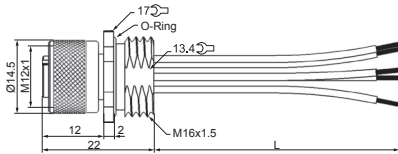
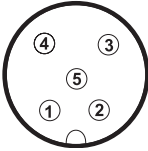

INTERFACE CABLES AND CONVERTORS

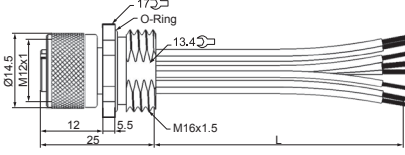
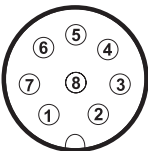
NAME	SUITABLE FOR	DESCRIPTION	ORDER CODE
Modbus configuration adapter 	EE354 EE355 EE364	For test and configuration with a PC, incl. supply adapter.	HA011013
	EE072 EE074 EE671 EE872	Connector A: USB Connector B: M12	HA011018
USB configuration adapter 	EE10 digital EE160 digital EE210 EE210-Outdoor EE211 EE4x1 digital EE600 digital EE610 digital EE650 EE660 EE800 EE820 EE850	For test and configuration with a PC, incl. supply adapter. Connector A: USB Connector B: 10 pole wire to board connector	HA011066
	USB adapter cable 	EE1900 EE1950	For test and configuration with a PC. Connector A: USB Connector B: 10 pole wire to board connector



CONNECTORS

NAME	SUITABLE FOR	DESCRIPTION	ORDER CODE															
Flange coupling, 5 pole 	EE07 EE060 type E9 EE072 EE074 EE872	M12x1 flange coupling L = 50 mm (2") ± 3 mm	HA010705															
	 <p>Connection diagram</p>  <table border="1"> <tr><td>1</td><td>brown</td></tr> <tr><td>2</td><td>white</td></tr> <tr><td>3</td><td>blue</td></tr> <tr><td>4</td><td>black</td></tr> <tr><td>5</td><td>grey</td></tr> </table> <p>front view</p>		1	brown	2	white	3	blue	4	black	5	grey						
1	brown																	
2	white																	
3	blue																	
4	black																	
5	grey																	
Flange coupling, 8 pole 	EE08 type D EE364	M12x1 flange coupling L = 2000 mm (2") ± 5 mm	HA010703															
	 <p>Connection diagram</p>  <table border="1"> <tr><td>1</td><td>white</td></tr> <tr><td>2</td><td>brown</td></tr> <tr><td>3</td><td>green</td></tr> <tr><td>4</td><td>yellow</td></tr> <tr><td>5</td><td>grey</td></tr> <tr><td>6</td><td>pink</td></tr> <tr><td>7</td><td>blue</td></tr> <tr><td>8</td><td>red</td></tr> </table> <p>front view</p>		1	white	2	brown	3	green	4	yellow	5	grey	6	pink	7	blue	8	red
1	white																	
2	brown																	
3	green																	
4	yellow																	
5	grey																	
6	pink																	
7	blue																	
8	red																	

CONNECTORS

NAME	SUITABLE FOR	DESCRIPTION	ORDER CODE
Connector, 4 pole socket 	EE07 EE060 type E9 EE072 EE074 EE741 EE820 Humlog 20 E	M12x1 cable connector, 4 pole, IP67 (NEMA 4), for self assembly	HA010707
Connector, 5 pole socket 	EE23 - C03 EE33 - C03/C08 EE75 - C12/C13 EE310 - E4, E6, E12, AM3 EE354 EE355 EE360 - E4, E6, E12, AM3 EE671 type T15 EE77x - type Q EE872 EE8915	M12x1 cable connector, 5 pole, IP67 (NEMA 4), for self assembly	HA010708
Connector, 8 pole socket 	EE08 type D EE364	M12x1 cable connector, 8 pole, IP67 (NEMA 4), for self assembly	HA010704
Connector, 5 pole plug 	EE310 / EE360: E5, E6, E12	M12x1 cable connector, 5 pole, IP67 (NEMA 4), for self assembly	HA010706



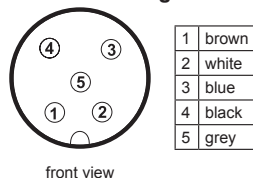

CABLES

NAME	SUITABLE FOR	DIMENSIONS / DESCRIPTION	ORDER CODE
Connection cable EE220/EE244 	EE07 with EE220 EE07 with EE244 EE244	5 pole, M12x1 plug-socket, shielded (shield connected to pin 5), PUR	HA010801 (2 m / 6.6 ft) HA010802 (5 m / 16.4 ft) HA010803 (10 m / 32.8 ft)
Connection cable, 5 pole 	EE771 EE772 EE776 Humlog 20 E	5 pole, M12x1 plug-socket, shielded, PUR	HA010816 (2 m / 6.6 ft) HA010817 (5 m / 16.4 ft) HA010818 (10 m / 32.8 ft)
Connection cable, 5 pole 	EE07 EE060 type E9 EE072 EE074 EE354 EE355 EE671 type T15 EE820 EE872 EE8915	5 pole, M12x1 socket - free ends, shielded, PUR	HA010819 (1.5 m / 4.9 ft) HA010820 (5 m / 16.4 ft) HA010821 (10 m / 32.8 ft)

Connection diagram

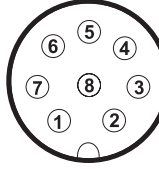

CABLES

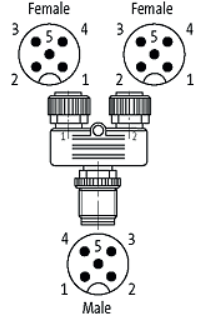
NAME	SUITABLE FOR	DIMENSIONS / DESCRIPTION	ORDER CODE																
Connection cable, 8 pole 	EE08 type D EE364	8 pole, M12x1 socket - free ends, shielded, PUR Connection diagram  front view <table border="1" data-bbox="837 448 933 660"> <tr><td>1</td><td>white</td></tr> <tr><td>2</td><td>brown</td></tr> <tr><td>3</td><td>green</td></tr> <tr><td>4</td><td>yellow</td></tr> <tr><td>5</td><td>grey</td></tr> <tr><td>6</td><td>pink</td></tr> <tr><td>7</td><td>blue</td></tr> <tr><td>8</td><td>red</td></tr> </table>	1	white	2	brown	3	green	4	yellow	5	grey	6	pink	7	blue	8	red	HA010322 (1.5 m / 4.9 ft) HA010323 (3 m / 9.8 ft) HA010324 (5 m / 16.4 ft) HA010325 (10 m / 32.8 ft)
1	white																		
2	brown																		
3	green																		
4	yellow																		
5	grey																		
6	pink																		
7	blue																		
8	red																		
Connection cable Omniport / Oilport / EE100Ex 	EE100Ex-T23 Omniport 30 Oilport 30	M12 connecting cable 4 pole, M12x1 plug-socket unshielded, PUR M12 connecting cable 5 pole, M12x1 plug-socket, unshielded, PUR	HA010826 (2 m / 6.6 ft) HA010813 (2 m / 6.6 ft) HA010814 (5 m / 16.4 ft) HA010815 (10 m / 32.8 ft)																
Protection cap 	M12 female connector		HA010781																
Protection cap 	M12 male connector		HA010782																
T-coupler M12-M12 	EE072 EE074 EE671 EE820 EE872 Humlog 20	T-coupler 1 male - 2 female for M12 5 pole connection	 HA030204																