

USER'S GUIDE

EE850 – CO₂ and Temperature Transmitter for Duct Mounting

GENERAL

The EE850 transmitters are designed for the measurement of carbon dioxide (CO₂) and temperature (T) in HVAC applications. It incorporates the E+E dual wavelength NDIR CO₂ sensor, which compensates for ageing effects, is highly insensitive to pollution and offers outstanding long term stability.

EE850 is available with CO₂ output only (0-10V or 4-20 mA), with CO₂ and T active outputs (0 – 10 V) or with CO₂ and T active outputs (0-10 V) and an additional passive T output.

For use in special applications do not hesitate to contact E+E Elektronik or a local distributor.

CAUTION

The transmitter shall not be exposed to extreme mechanical or thermal stress.

This device is not appropriate for safety, emergency stop or other critical applications where device malfunction or failure could cause injury to human beings.

OPERATION PRINCIPLE

Installed into a duct, a small amount of air will flow through the divided probe into the EE850 transmitter housing, where the CO₂ sensing cell is located, and back into the duct. The temperature sensor is located inside the probe.

Very important

For accurate measurement the cover of EE850 as well as the cable outlet – cable gland or conduit adapter - must be tightly closed. This is essential for avoiding ingress of air other than from the duct into the EE850 enclosure, which would falsify the measurement.

The direction of the air flow in the duct shall correspond to the direction indicated with arrows on the cover of EE850.

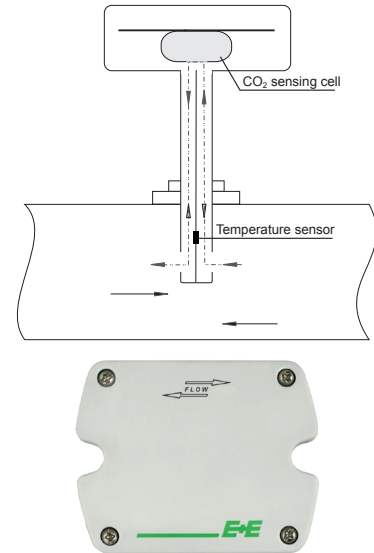

INSTALLATION

EE850 with cable gland: Use a matching wrench to install the cable gland (in the scope of supply) onto the EE850 enclosure. While doing this the blind will knock open. Do not use other tools to knock open the blind in order to avoid damaging the electronics inside the enclosure.

EE850 with conduit connection for the North American market: Use a flat screwdriver carefully to knock open the blind at the marked location, in order to avoid damaging the electronics inside the enclosure. The conduit adapter is not included in the scope of supply.

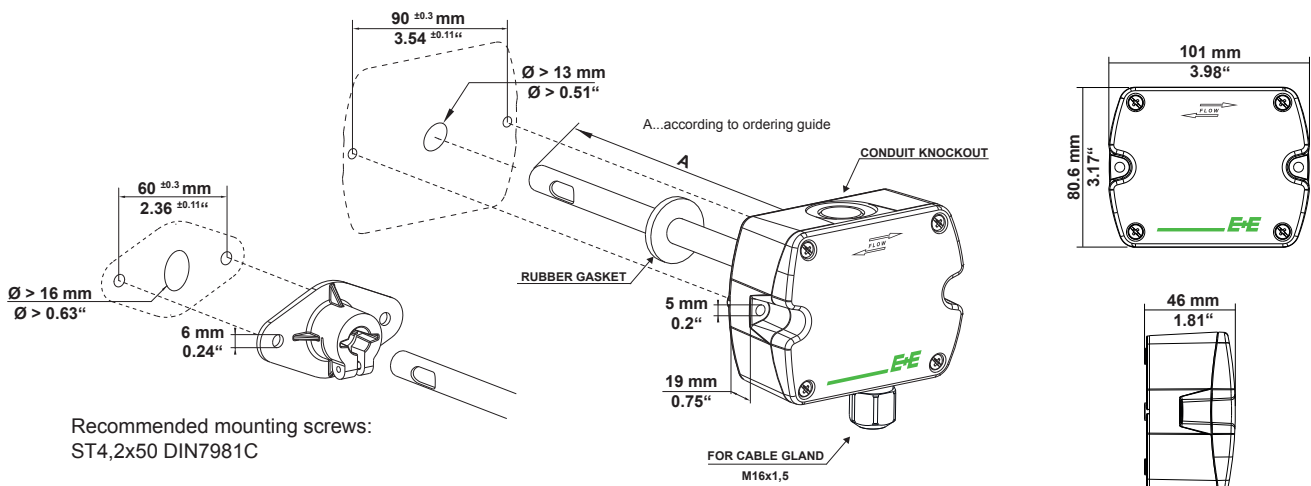

CONNECTION DIAGRAM

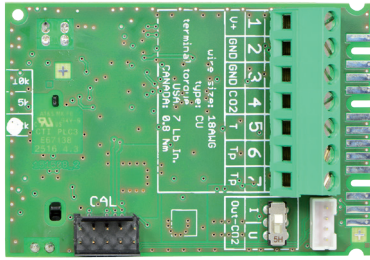

Voltage output

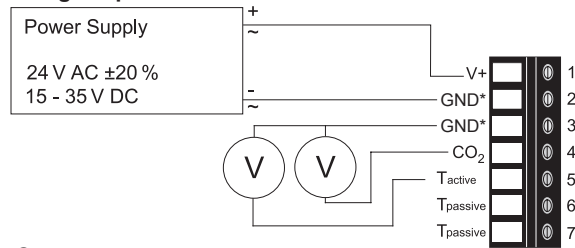

Current output

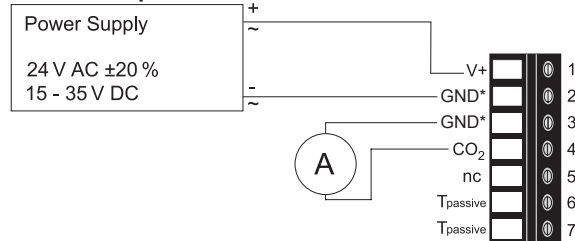

* **Very important:** for failure-free operation and performance according to the specs the supply GND and the measurement GND must be wired separately.

TECHNICAL DATA

(Modification rights reserved)

Measuring Values

CO₂

Measurement principle	dual wavelength non-dispersive infrared technology (NDIR)
Measuring range	0...2000 / 5000 / 10000 ppm
Accuracy at 25 °C (77 °F) and 1013 mbar (14.7 psi)	0...2000 ppm: < ± (50 ppm +2% of measured value) 0...5000 ppm: < ± (50 ppm +3% of measured value) 0...10000 ppm: < ± (100 ppm +5% of measured value)

Response time τ_{63}	< 100 s at 3 m/s (590 ft/min) air speed in the duct
Temperature dependency	typ. ± (1 + CO ₂ concentration [ppm] / 1000) ppm/°C (-20...45 °C) (-4...113 °F)
Calibration interval ¹⁾	>5 years
Sample rate	approx. 15 s

Temperature

Working range	-20...60 °C (-4...140 °F); scaling see ordering guide
Accuracy at 20 °C (68 °F)	±0.3 °C (±0.54 °F)
Response time τ_{63}	< 50 s

Outputs

Analogue Output

CO ₂ : 0...2000 / 5000 / 10000 ppm	$\left\{ \begin{array}{l} 0 - 5 / 0 - 10 \text{ V} \quad -1 \text{ mA} < I_L < 1 \text{ mA} \\ 4 - 20 \text{ mA} \quad R_L < 500 \text{ Ohm} \end{array} \right.$
T: according ordering guide	

Passive T-Output

2-wire	see ordering guide
Wires resistance (terminal - sensor)	typ. 0.4 Ohm

General

Supply voltage	24 V AC ±20% 15 - 35 V DC
Current consumption	typ. 15 mA + output current max. 350 mA for 0.3 s
Min. flow speed	1 m/s (196 ft/min) recommended
Housing material	Polycarbonate, UL94V-0 approved
Protection class	Enclosure: IP65 / NEMA 4, probe: IP20
Cable gland	M16 x 1.5
Electrical connection	screw terminals max. 2.5 mm ² (AWG 14)
Electromagnetic compatibility	EN61326-1 EN61326-2-3 Industrial Environment FCC Part 15 ICES-003 ClassB
Working and storage conditions	-20...60 °C (-4...140 °F) 0...95 % RH (non-condensing)

1) under normal operating conditions



SETUP AND ADJUSTMENT

The EE850 transmitter is ready to use and does not require any configuration by the user. The factory setup of EE850 corresponds to the type number ordered. For ordering guide please see data sheet at www.epluse.com/EE850

If needed, the user can change the factory setup by using the optional Product Configuration Adapter EE-PCA and the Product Configuration Software EE-PCS. One can change the CO₂ output signal, the scaling of the outputs and perform CO₂ and T adjustment/calibration.

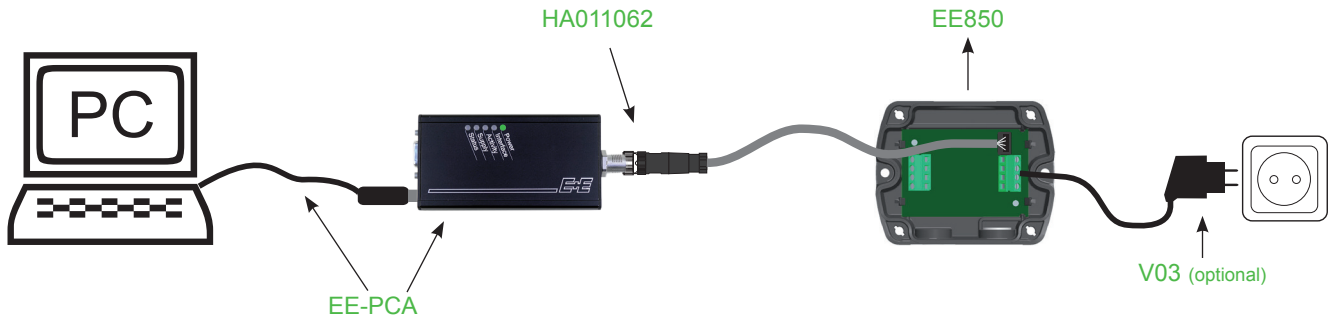

Changing the CO₂ output signal:

The output signal can be changed from voltage to current or vice-versa. (The T output can only be voltage)

Set the output signal selection switch to I for current 4 - 20 mA output or to U for voltage 0 - 10 V output. The original CO₂ output range does not change and the calibration data remains valid.

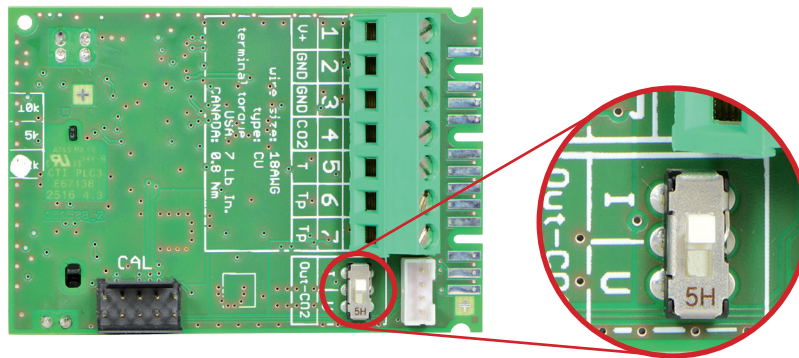

Example:

Factory setup: voltage output (U), output scale: 0 - 10 V = 0 - 5000 ppm

User setup (after setting the output signal selection switch to I): current output (I), output scale: 4 - 20 mA = 0 - 5000 ppm.

Changing the CO₂ and T output scale:

The scaling of the output can be changed by using EE-PCA and EE-PCS.

Example:

The initial scaling of the outputs is:

CO₂: 0 - 10 V = 0 - 5000 ppm

T: 0 - 10 V = 0 - 50 °C

The output scale after the change is:

CO₂: 0 - 10 V = 400 - 4000 ppm

T: 0 - 10 V = 40 - 100 °F

Important:

- After changing the factory setup (output signal and/or output scale) the original type number on the EE850 identification label loses its validity; it does not match any longer the device setup.
- The return to factory setup function of EE-PCS restores the original adjustment/calibration of the device, but does not affect the user setup for output signal and output scale.

For EE-PCA product data sheet please see www.epluse.com/EE850

The EE-PCS Product Configuration Software is available for free download at www.epluse.com/configurator.

SCOPE OF SUPPLY

- EE850 transmitter according ordering guide
- Cable gland
- Mounting flange + seal
- Mounting materials
- Two self-adhesive labels for configuration changes (see user guide at www.epluse.com/relabeling)
- Test report according to DIN EN10204 - 2.2

USA

FCC notice:

This equipment has been tested and found to comply with the limits for a Class B digital device, pursuant to part 15 of the FCC Rules. These limits are designed to provide reasonable protection against harmful interference in a residential installation. This equipment generates, uses and can radiate radio frequency energy and, if not installed and used in accordance with the installation manual, may cause harmful interference to radio communications. However, there is no guarantee that interference will not occur in a particular installation. If this equipment does cause harmful interference to radio or television reception, which can be determined by turning the equipment off and on, the user is encouraged to try to correct the interference by one or more of the following measures:

- Reorient or relocate the receiving antenna.
- Increase the separation between the equipment and receiver.
- Connect the equipment into an outlet on a circuit different from that to which thereceiver is connected.
- Consult the dealer or an experienced radio/TV technician for help.

CANADIAN

ICES-003 Issue 5:

CAN ICES-3 B / NMB-3 B

INFORMATION

+43 7235 605 0 / info@epluse.com

Langwiesen 7 • A-4209 Engerwitzdorf
Tel: +43 7235 605-0 • Fax: +43 7235 605-8
info@epluse.com • www.epluse.com

LG Linz Fn 165761 t • UID-Nr. ATU44043101
Place of Jurisdiction: A-4020 Linz • DVR0962759

