

Instruction for use

021317/05/07

Brightness Transmitter

- direction-independent

7.1414.40.xxx



Contents

1	Models.....	2
2	Range of Application.....	2
3	Mode of Operation.....	3
4	Mounting.....	3
5	Maintenance.....	3
6	Connecting Diagram.....	4
7	Technical Data.....	5
8	Temperature Diagram (only for instruments with heating)	5
9	Dimensional drawing	6
10	EC-Declaration of Conformity.....	7

1 Models

Order - No.	Meas. Range	Electr. Output	Supply Voltage	Heating voltage
7.1414.40.002	0...100 000 Lux	0...10 V	18... 36 V DC or 18... 24 V AC	without heating
7.1414.40.102	0...100 000 Lux	0...10 V	18... 36 V DC or 18... 24 V AC	24 V AC or 24 V DC
7.1414.40.112	0...10 000 Lux	0...10 V	18... 36 V DC or 18... 24 V AC	24 V AC or 24 V DC
7.1414.40.141	0.....1 000 Lux	4 ... 20 mA	18... 36 V DC or 18... 24 V AC	24 V AC or 24 V DC
7.1414.40.152	0.....5 000 Lux	0 ... 10 V	18... 36 V DC or 18... 24 V AC	24 V AC or 24 V DC

2 Range of Application

The direction-independent brightness transmitter is adapted to the sensitivity of the human eye, and serves for the acquisition of the brightness.

The output signal of the brightness transmitter is delivered as light-proportional voltage, and is used, for example, as input signal for the regulation of shading devices, heating- and irrigation plants in automatically controlled green houses.

3 Mode of Operation

Through the sensor, and a connected electronic system the falling daylight is converted into a proportional output dimension. Thanks to its special construction the sensor achieves an almost direction-independent sensibility in the elevation angle (height of 0° up to 90°, and in the azimuth of 0° up to 360°. In order to avoid a possible dewing the model 7.1414.40.102 can be heated.

4 Mounting

The Brightness Transmitter is designed to be mounted to a horizontal surface out-of-doors. To do so, first unscrew the cover of the case. Mount the instrument using respective screws through the now accessible boreholes.

Use a shielded LiYCY 6x0.25 mm² cable to connect the instrument electrically. For the brightness transmitter without heating you can use LiYCY 4x0,5 mm² cable. Lead the cable through the screw-type conduit fitting and place it on the terminal strip as given in the connecting diagram. Ground the shielding.

Mounting Instruction:

When mounting the instrument, please take into consideration that this sensor evaluates also laterally falling light, and accumulates it to the directly falling sunlight. If the brightness transmitter is mounted horizontally in front of a strongly reflecting vertical wall, the measuring values are considerably higher than they would be in the free field, or in front of a hardly reflecting surface.

Attention:

The output voltage of this brightness sensor can be compared only with brightness measuring transmitters showing no cosine action in the elevation angle of 0° up to 90°, and measuring independently from direction also in the azimuth of 0° up to 360°.

5 Maintenance

Clean the light dome at regular intervals – depending on the extent of soiling – with a soft cloth and pure water (no additives).

6 Connecting Diagram

7.1414.40.002

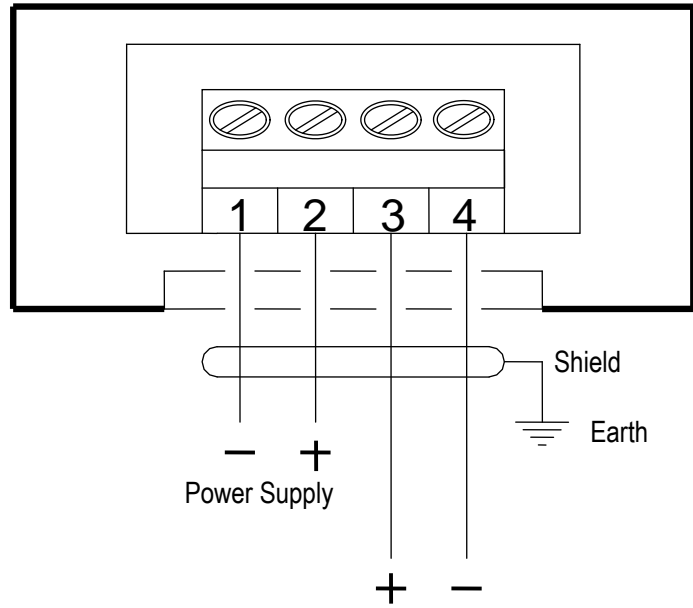

18...36 V DC
oder
18...24 V AC

Electrical
Output

7.1414.40.102
7.1414.40.112
7.1414.40.141
7.1414.40.152

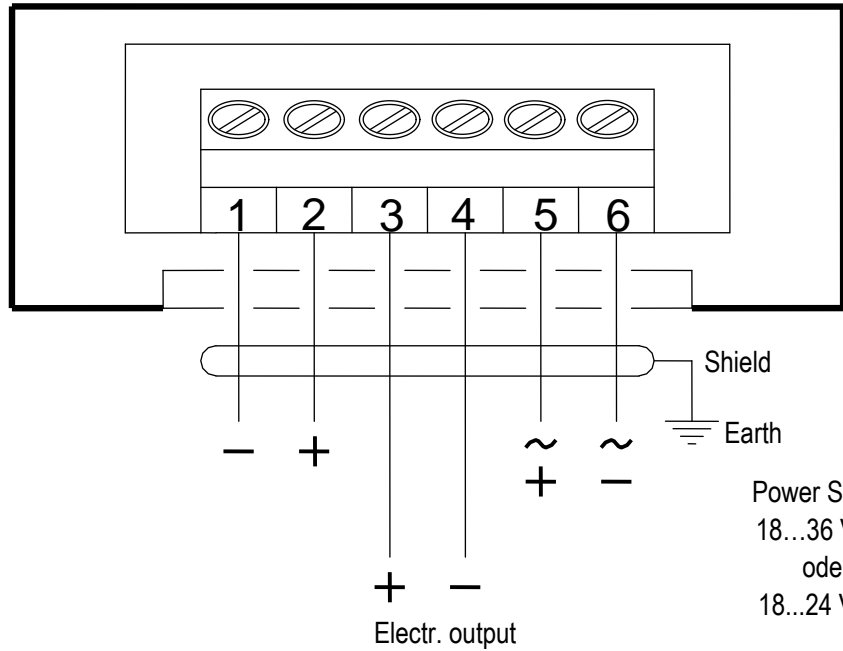

Power Supply
18...36 V DC
oder
18...24 V AC

Pover S
Heati
24 V AC

7 Technical Data

Measuring Range	see model
Electrical output	see model
Sensor type	BPW 21
Accuracy	± 2% of calibration norm
Spectral range	350...820 nm
Acquisition	
Angel Elevation	0...90°
Azimuth	0... 360°
Electrical Output	shortcut- safe output
voltage [U]	0...10 V
current [I]	4...20 mA
Operating voltage	
Electronic	18...36 V DC or 18 ... 24 V AC
Heating	24 V AC or 24 V DC
Load	≥ 1000 Ω with voltage- output [U] ≤ 500 Ω with current- output [I]
Current consumption of electronics heating	approx. 10 mA, unloaded max. 300 mA
Ambient temperature	- 30...+ 70° C
Dimension	see Dimensional drawing
Protection	IP 65
Weight	approx. 150g
Connection	via cable screwing M16 x 1.5

8 Temperature Diagram (only for instruments with heating)

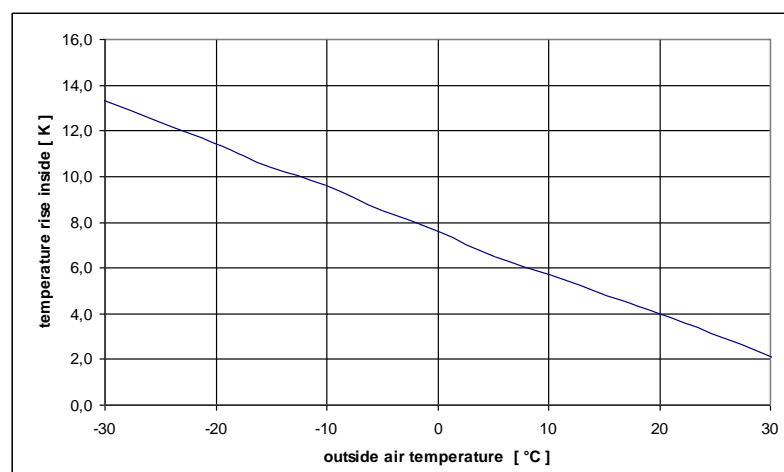

Outside - inside – difference temperature by using the heating.

When the outside temperature is falling the heating capacity raises.

At a power supply of 24 V the heating current is flowing as follows:

approx. 20 mA at 30 °C, and approx. 140 mA at –30 °C

The raised inside temperature prevents the light dome from being moistened by dew.

9 Dimensional drawing

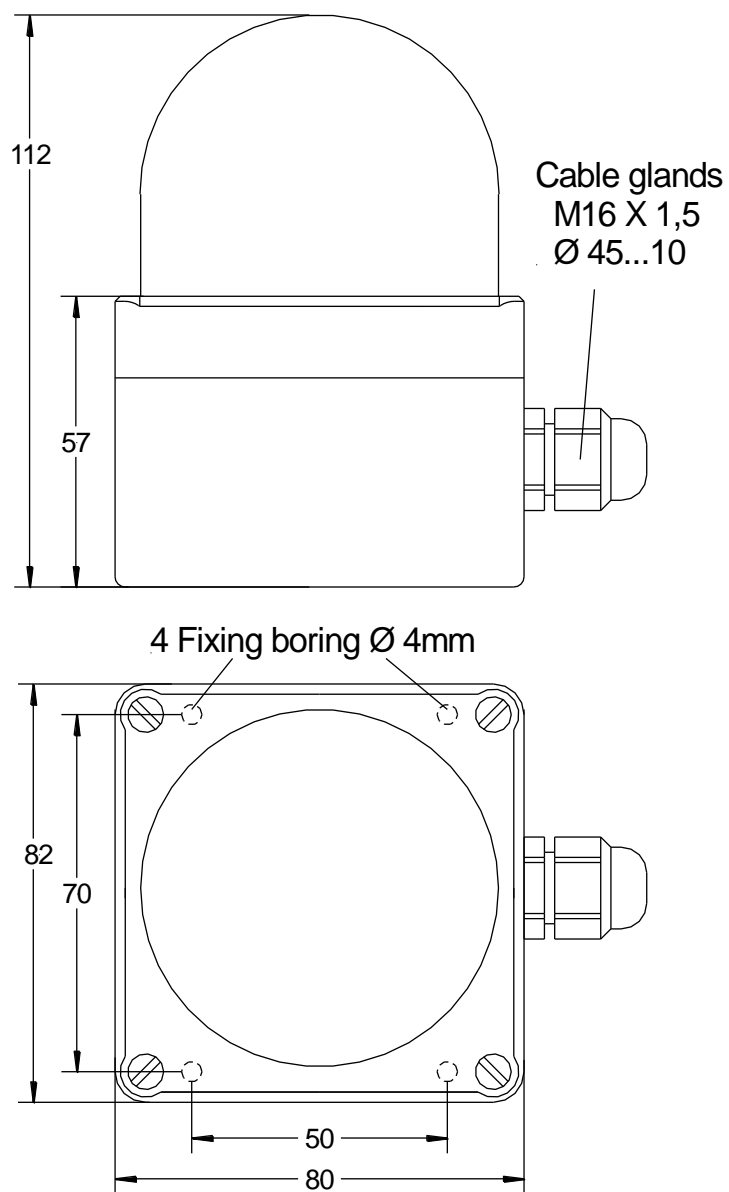

10 EC-Declaration of Conformity

Document-No.: **000318**

Month: 08 Year: 08

Manufacturer: **ADOLF THIES GmbH & Co. KG**

Hauptstr. 76
D-37083 Göttingen
Tel.: (0551) 79001-0
Fax: (0551) 79001-65
email: Info@ThiesClima.com

Description of Product: **Brightness Transmitter**

Article No.	7.1414.10.003	7.1414.10.040	7.1414.10.041	7.1414.10.061
	7.1414.10.541	7.1414.10.561	7.1414.10.941	7.1414.12.040
	7.1414.12.041	7.1414.12.061	7.1414.15.040	7.1414.15.041
	7.1414.15.061	7.1414.22.040	7.1414.22.041	7.1414.22.061
	7.1414.25.040	7.1414.25.041	7.1414.25.061	7.1414.40.002
	7.1414.40.102	7.1414.40.103	7.1414.40.112	7.1414.40.141
	7.1414.40.152	7.1414.51.150	7.1414.51.550	
	7.1414.60.000	7.1414.61.000		

specified technical data in the document: **020923/05/07; 021316/05/07; 021327/04/03; 021524/05/07; 021458/08/06**

The indicated products correspond to the essential requirement of the following European Directives and Regulations:

- 2004/108/EC DIRECTIVE 2004/108/EC OF THE EUROPEAN PARLIAMENT AND OF THE COUNCIL of 15 December 2004 on the approximation of the laws of the Member States relating to electromagnetic compatibility and repealing Directive 89/336/EEC
- 2006/95/EC DIRECTIVE 2006/95/EC OF THE EUROPEAN PARLIAMENT AND OF THE COUNCIL of 12 December 2006 on the harmonisation of the laws of Member States relating to electrical equipment designed for use within certain voltage limits
- 552/2004/EC Regulation (EC) No 552/2004 of the European Parliament and the Council of 10 March 2004 on the interoperability of the European Air Traffic Management network (the interoperability Regulation)

The indicated products comply with the regulations of the directives. This is proved by the compliance with the following standards:

Reference number	Specification
IEC 61000-6-2: 2005	Electromagnetic compatibility Immunity for industrial environment
IEC 61000-6-3: 2006	Electromagnetic compatibility Emission standard for residential, commercial and light industrial environments
IEC 61010-1: 2001	Safety requirements for electrical equipment for measurement, control and laboratory use. Part 1: General requirements

Place: Göttingen

Date: 05.08.2008

Legally binding signature:

issuer:

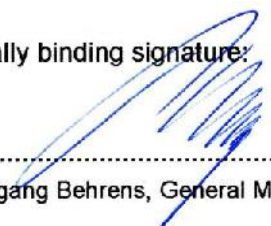
.....
Wolfgang Behrens, General Manager

.....
Joachim Beinhorn, Development Manager

This declaration certifies the compliance with the mentioned directives, however does not include any warranty of characteristics. Please pay attention to the security advises of the provided instructions for use.



Official BeNeLux distributor: www.catec.nl



- Alterations reserved-