

Instructions for Use

021772/09/14

Silicon Pyranometer GSM 3.3

7.1415.09.xxx



ADOLF THIES GmbH & Co. KG

Hauptstraße 76 37083 Göttingen Germany
Box 3536 + 3541 37025 Göttingen
Phone +49 551 79001-0 Fax +49 551 79001-65
www.thiesclima.com info@thiesclima.com

Safety Instructions

- Before operating with or at the device/product, read through the operating instructions. This manual contains instructions which should be followed on mounting, start-up, and operation. A non-observance might cause:
 - failure of important functions
 - Endangering of persons by electrical or mechanic effect
 - Damages at objects
- Mounting, electrical connection and wiring of the device/product must be carried out only by a qualified technician who is familiar with and observes the engineering regulations, provisions and standards applicable in each case.
- Repairs and maintenance may only be carried out by trained staff or **Adolf Thies GmbH & Co. KG**. Only components and spare parts supplied and/or recommended by **Adolf Thies GmbH & Co. KG** should be used for repairs.
- Electrical devices/products must be mounted and wired only in voltage-free state.
- **Adolf Thies GmbH & Co KG** guarantees proper functioning of the device/products provided that no modifications have been made to the mechanics, electronics or software, and that the following points are observed:
- All information, warnings and instructions for use included in these operating instructions must be taken into account and observed as this is essential to ensure trouble-free operation and a safe condition of the measuring system / device / product.
- The device / product is designed for a specific application as described in these operating instructions.
- The device / product should be operated with the accessories and consumables supplied and/or recommended by **Adolf Thies GmbH & Co KG**.
- Recommendation: As it is possible that each measuring system / device / product under certain conditions, and in rare cases, may also output erroneous measuring values, it is recommended to use redundant systems with plausibility checks with **security-relevant applications**.

Environment

- As a longstanding manufacturer of sensors Adolf Thies GmbH & Co KG is committed to the objectives of environmental protection and is therefore willing to take back all supplied products governed by the provisions of "*ElektroG*" (German Electrical and Electronic Equipment Act) and to perform environmentally compatible disposal and recycling. We are prepared to take back all Thies products concerned free of charge if returned to Thies by our customers carriage-paid.
- Make sure you retain packaging for storage or transport of products. Should packaging however no longer be required, arrange for recycling as the packaging materials are designed to be recycled.



Documentation

- © Copyright **Adolf Thies GmbH & Co KG**, Göttingen / Germany
- Although this operating instruction has been drawn up with due care, **Adolf Thies GmbH & Co KG** can accept no liability whatsoever for any technical and typographical errors or omissions in this document that might remain.
- We can accept no liability whatsoever for any losses arising from the information contained in this document.
- Subject to modification in terms of content.
- The device / product should not be passed on without the/these operating instructions.

Contents

1	Models	4
2	Application	4
3	Construction.....	5
4	Installation.....	5
5	Maintenance	5
6	Connecting diagram.....	6
7	Serial interface.....	7
7.1	THIES command interpreter.....	7
7.2	Command interpreter MODBUS RTU.....	11
7.3	Commands and description.....	14
8	Technical data	18
9	Dimension diagram	19
10	EC Declaration of Conformity	20
11	Accessories (optional).....	21

1 Models

Designation	Order No.	Meas. range [W/m ²]	Spectral range [nm]	Interface		Data format	Operating voltage
				analog	digital		
Silicon Pyranometer GSM 3.3	7.1415.09.240	0...1300	400...1100	0...20mA	RS485	ASCII format (command interpreter: THIES)	9...28VDC
	7.1415.09.241			4...20mA			
	7.1415.09.251			0...5V			
	7.1415.09.261			0...10V			
Silicon Pyranometer GSM 3.3	7.1415.09.340	0...1300	400...1100	0...20mA	RS485	Binary format (command interpreter: MODBUS RTU)	9...28VDC
	7.1415.09.341			4...20mA			
	7.1415.09.351			0...5V			
	7.1415.09.361			0...10V			
Silicon Pyranometer GSM 3.3	7.1415.09.041	0...1300	400...1100	4...20mA	-----	-----	9...28VDC (2-wire circuit)

Scope of supply:

- Pyranometer
- Cable
- Set of operating instructions

2 Application

Global radiation is the sum of direct solar radiation and diffuse radiation reaching the surface of the earth. The spectral range extends from the short-wave-range at 300nm (UV-B) to the long-wave-range at 5000nm (IR).

The pyranometer detects almost 90% of the sunlight-spectra in the **range from 400nm to 1100nm**, and thus, comprises the uv-(ultraviolet radiation), vis-(visible radiation), and the part of the ir-(Infrared-radiation) light.

The measuring results give information about medical and biological cohesions, compared with other spectral ranges.

The pyranometer can be used in the fields of medical and biological research, with weather information and prognosis systems, in the climatic research, in the field of agriculture, and for the general information of the population.

Besides the analog output 7.1415.09.2xx / 3xx are also equipped with a serial interface (RS485) for data transmission in half duplex mode. Together with ID-based communication, the interface allows the pyranometer to be operated in a bus. Two data protocols are available here:

- ASCII (THIES format)
- Binary (MODBUS RTU)

3 Construction

The pyranometer is a fragile electronic-optical device. The housing is made of anodized aluminium with an uv-transparent PMMA dome. The instrument is protected against jets of water and rain. A small package of silica-gel serves for drying the inner housing and protects the dome against steaming-up. The results are cosine-corrected.

4 Installation

The mounting shall be effected with greatest care. The pyranometer is fixed with two screws M4 onto a suited holder, and should be exactly in horizontal position. The mounting site should be selected in a way, that the sun radiation reaches the surface of the sensor all day. The pyranometer must have a free horizon into all directions. The instrument marking must indicate to Northern direction.

For the data transmission please use the cable available. For the connector pin assignment please refer to chapter 6. When connecting the cable coupling to the pyranometer please take care that the mounting notches of coupling and plug coincide. The cap nut is to be screwed tightly.

5 Maintenance

The electronic-optical part of the pyranometer needs no service. A check of the calibration is possible acc. to the customer's request. The PMMA-dome, and the housing are to be cleaned, if necessary, with a soft and wet cloth twice a year. Please use only liquid cleaning agents without abrasive additives or solvents. The outer cleaning should be done with clear water or possibly with washing-up liquid.

6 Connecting diagram

Please note:

With long transmission paths connection to the GND of data acquisition may reduce their susceptibility to interference. There should not be any electrical connection between power GND and DATA-GND.

Order No.	Diagram: supply / output	Wiring diagram
7.1415.09.041	<p>Diagramm / Diagram RL als Funktion der Versorgungsspannung RL as function of Power Supply</p>	<p>Pyranometer 5 pol. Stecker / Plug 1 2 3 4 5 Erde / Earth RL 4 ... 20 mA = 0 ... 1300 W / m² + - Versorgung Power Supply siehe Diagramm / see Diagram</p>

	Supply	Analog output	Serial output RS 485			Wiring diagram
Order No.	PIN 1, 2	PIN 3, 4	PIN 5	PIN 6	PIN 7	
7.1415.09.240 7.1415.09.340	9...28VDC	0...20mA	Data -	Data +	DATA-GND	<p>Pyranometer 8 pol. Stecker / Plug 1 2 3 4 5 6 7 8 Erde / Earth Data GND Data + Data - RS 485 + - Ausgang / Output Analog + - Versorgung Power Supply</p>
7.1415.09.241 7.1415.09.341	9...28VDC	4...20mA	Data -	Data +	DATA-GND	
7.1415.09.251 7.1415.09.351	9...28VDC	0...5V	Data -	Data +	DATA-GND	
7.1415.09.261 7.1415.09.361	12...28VDC	0...10V	Data -	Data +	DATA-GND	

7 Serial interface

The interface to the weather station takes the form of an RS485 connection (half duplex mode), with the following data format:

- 9600 baud (the baud rate can be selected with **Command BR**)
- 8 data bits
- no parity
- 1 stop bit
- data in ASCII format (command interpreter: THIES)
- data in binary format (command interpreter: MODBUS RTU)

The behaviour (configuration) of the weather station can be changed with the commands available (see Commands and description). With the command interpreter of the type THIES the measured values are queried with Command TR.

When the pyranometer starts, the character string "Pyranometer" is output together with the software version and serial number.

Example: Pyranometer
 v00.01
 12030123

7.1 THIES command interpreter

The pyranometer is equipped a command interpreter of the type THIES, which can be used to change the behaviour of the device. A command basically has the following structure:

- `<id><command><CR>` (without parameter: used to query the selected parameter)
- `<id><command><parameter><CR>` (with parameter: used to set a new parameter)

id: identification number ("00" to "99")
command: command consisting of 2 characters (see list of commands)
parameter: parameter value with 1 to 10 positions (decimal value in shown in ASCII)
<CR>: carriage return (13_{dec}; 0x0D)

The identification number 'id' allows several devices to be operated together in the bus system. Every device is allocated its own 'id' (see **Command ID**).

A transmitted command is acknowledged with a corresponding echo telegram. The echo telegram starts with an "!", followed by the id, the command and the value selected. This is then followed by the characters "carriage return" and "new line".

Commands can be transmitted either with or without parameters. If no parameter is specified, the value selected is output.

Example: 00BR<CR>
 !00BR00096<CR>

If a command is transmitted with a parameter, the parameter is checked. If the parameter is valid, it is stored and specified in the "echo telegram". If the parameter is invalid, the parameter is disregarded and the selected value output in the "echo telegram".

Examples:

00BR00096<CR>	transmission command
!00BR00096<CR>	echo telegram (parameter valid and password Ok)
00BR00048<CR>	transmission command
!00BR00096<CR>	echo telegram (parameter valid but key incorrect)

Please note:

The command TR can be used to query the values measured by the sensors.

Here the weather station does not respond with the echo telegram, but with the requested data telegram!

To avoid any inadvertent erroneous change in parameters, some commands (see list of commands) are password-protected. This password must be transmitted before the actual command.

Example: Change baud rate

00KY234<CR>	Release user-level commands
00BR48<CR>	Set baud rate to 4800
!00BR00048<CR>	Set baud rate to 4800

The pyranometer supports 3 different password levels.

- user-level (password: "234")
- calibration data level
- administrator level

Please note:

Password-protected commands are released as long as one of the following conditions is satisfied:

- supply voltage switched***
- command 00KY0<CR> transmitted***
- no new command transmitted for min. 120s***

7.1.1 Data telegrams

Data is output on request using the command TR:

- measured value telegram (parameter=1)

Calculation of the checksum, composition of the status word and the control characters/separators used in the telegrams are described below.

Control characters:

CR – carriage return (13_{dec}; 0x0D)

LF – line feed (10_{dec}; 0x0A)

STX – start of text (2_{dec}; 0x02)

ETX – end of text (3_{dec}; 0x03)

Separators:

The individual measured values appearing in the string are separated by a semicolon ';'.
The multiplication sign '*' is used as the check sum separator.

Checksum:

The checksum is the XOR link of all characters between <STX> and the byte <*>.
The asterisk serves as a separator from the check sum and is not included in it.

Status:

A status word (16 bits) is available in the pyranometer, providing information about its status.

Bit number	Function	Description
Bit 0	Amplification x1	=1, amplification x1 active
Bit 1	Amplification x2	=1, amplification x2 active
Bit 2	Amplification x64	=1, amplification x64 active
Bit 3	Amplification x128	=1, amplification x128 active
Bit 4	A/D conversion rate 10SPS	=1, conversion rate of ADC is 10SPS
Bit 5	A/D conversion rate 80SPS	=1, conversion rate of ADC is 80SPS
Bit 6	Source radiation computation	=0, thermocouples =1, photodiode
Bit 7	-	-
Bit 8	-	-
Bit 9	-	-
Bit 10	-	-
Bit 11	-	-
Bit 12	-	-
Bit 13	-	-
Bit 14	-	-
Bit 15	-	-

Table 1 : Status word

7.1.1.1 Measured value telegram

The pyranometer responds to the command "00TR1\r" with the measured value telegram. The telegram structure is shown in the following table.

Position	Length	Example	Description
1	1	<STX>	Start of text character (0x02)
2	11	PYRANOMETER	Text
13	1	;	Semicolon
14	2	##	Identification number of pyranometer
16	1	;	Semicolon
17	6	#####.	Global radiation (W/m ²)
23	1	;	Semicolon
24	5	####.	Inside temperature of housing (°C)
29	1	;	Semicolon
30	10	#####	Operating time (s)
40	1	;	Semicolon
41	4	####	16-bit sensor status in hexadecimal format (0000 – FFFF)
45	1	*	Asterisk as separator from checksum
47	2	##	8-bit checksum in hexadecimal format (00 – FF). The checksum is calculated from the exclusive OR link of all characters after STX to the character before "**"
48	1	<ETX>	End of text character (0x03)
49	1	<CR>	Carriage return (0x0D)
50	1	<LF>	Line feed (0x0A)

7.2 Command interpreter MODBUS RTU

If the command interpreter MODBUS RTU is selected, the bytes transmitted are interpreted according to the MODBUS specification (<http://www.modbus.org/>). Here the pyranometer represents a MODBUS slave.

Data is transmitted in packets, known as frames, of max. 256 bytes. Each packet contains a 16-bit CRC checksum (initial value: 0xffff).

Slave address	Function code	Data	CRC	
1 byte	1 byte	0...252 byte(s)	2 bytes	
			CRC low-byte	CRC high-byte

MODBUS frame

The following MODBUS functions are supported:

- 0x04 (Read input register)
- 0x03 (Read holding registers)
- 0x06 (Write single register)
- 0x10 (Write multiple registers)

The pyranometer supports write accesses for the slave address 0 ("Broadcast").

All MODBUS requests received are checked for validity before execution. In the event of an error the pyranometer responds with one of the following exceptions (→MODBUS exception responses).

Code	Name	Meaning
0x01	ILLEGAL FUNCTION	The function code in the request is not permitted for the register address.
0x02	ILLEGAL DATA ADDRESS	The register address in the request is not valid.
0x03	ILLEGAL DATA VALUE	The data specified in the request is not permitted.

MODBUS exceptions

7.2.1 Measured values (input register)

All measured values of the pyranometer occupy 32 bits, i.e. 2 MODBUS register addresses. The following table shows the assignment of measured values to register addresses, with the measured values being sorted as follows:

- by type of measured value (30001 to 34999)
- as an uninterrupted sequence (35001 to 39999)

Register-address	Parameter name	Unit	Multiplier	Explanation	Data type
30403	Inside temperature of housing	°C	10	Value / 10 (1 decimal place, e.g. 355=35.5°C)	S32
31001	Global radiation	W/m ²	10	Value / 10 (1 decimal place, e.g. 10000=1000.0W/m ²)	S32
34811	Sensor status		1	Value (no decimal place, bit coded, dep. on sensor)	U32
34813	Main executed loops per 1s	1/s	1	Value (no decimal place, e.g. 2550=2550 1/s)	U32
34815	Operating time	s	1	Value (no decimal place, e.g. 255=255s)	U32
35001	Inside temperature of housing (30403) ¹	°C	10	Value / 10 (1 decimal place, e.g. 355=35.5°C)	S32
35003	Global radiation	W/m ²	10	Value / 10 (1 decimal place, e.g. 10000=1000.0W/m ²)	S32
35005	Sensor status (34811) ¹		1	Value (no decimal place, bit coded, dep. on sensor)	U32
35007	Main executed loops (34813) ¹	1/s	1	Value (no decimal place, number of loops per 1s)	U32
35009	Operating time (34815) ¹	s	1	Value (no decimal place, e.g. 255=255s)	U32
35011	Voltage of thermocouple	mV	1000000	Value / 1000000 (1 decimal place, e.g. 20000000=20mV)	S32
35013	Voltage of photodiode	mV	1000000	Value / 1000000 (1 decimal place, e.g. 20000000=20mV)	S32

MODBUS input register

¹: The numbers in brackets designate register addresses which represent the same measured values, i.e. Inside temperature of housing for example is at Address 30403 and Address 35013.

Please note:

Due to uninterrupted sequencing of the measured values from address 35001, the MODBUS Master can read out all measured values with one request!

7.2.2 Commands (holding register)

All commands of the pyranometer occupy 32 bits, i.e. 2 MODBUS register addresses and represent unsigned whole numbers. The following example shows changing the baud rate to 19200 baud.

1. Set password for user level (KY=234)

Slave address	Function code	Start address	No. of registers	No. of bytes(s)	Data	CRC	
0x01	0x10	0x9C 49	0x00 02	0x04	0x00 00 00 EA	0x4F 7C	
						CRC low-byte	CRC high-byte

2. Command Set baud rate to 19200 baud (BR=6)

Slave address	Function code	Start-address	No. of registers	No. of bytes(s)	Data	CRC	
0x01	0x10	0x9C 45	0x00 02	0x04	0x00 00 00 06	0x4E A4	
						CRC low-byte	CRC high-byte

7.3 Commands and description

The following table shows the available commands together with the associated passwords for Read and Write.

Command	MODBUS register address	Description	Password	
			Read ¹	Write ²
Command BR	40005	Select baud rate	Without	User
Command CI	40013	Command interpreter	Without	User
Command FB	40001	Quick-start mode	Without	User
Command ID	40003	Identification number / slave address	Without	User
Command KY	40009	Set key / password	Without	Without
Command SA	40039	Scaling for minimum value of analog output	Without	User
Command SB	40041	Scaling for maximum value of analog output	Without	User
Command SV	45005	Software version	Without	--
Command TR	-	Telegram output	Without	Without

7.3.1 Command BR

<id>BR<parameter><CR> Select baud rate

Access: Read / write

Description: The command BR is used to select the required baud rate.

Parameter description:

Parameter	Description
12	1200 baud (8n1)
24	2400 baud (8n1)
48	4800 baud (8n1)
96	9600 baud (8n1)
192	19200 baud (8n1)
384	38400 baud (8n1)
576	57600 baud (8n1)

Value range: 12 / 24 / 48 / 96 / 192 / 384 / 576 / 1152

Initial value: 96

7.3.2 Command CI

<id>CI<parameter><CR> Select command interpreter

Access: Read / write

Description: The command CI is used to select the command interpreter required.

Please note:

If the identification number (ID) is greater than 98, it will be automatically set to 0 on switchover to the THIES interpreter!

Please note:

If the identification number (ID) is equal to 0, switchover to the MODBUS RTU interpreter is not possible!

Parameter description:

Parameter	Description
0	THIES
1	MODBUS RTU

Value range: 0 to 1

Initial value: 0

7.3.3 Command FB

<id>FB<parameter><CR> Quick-start mode

Access: Read / write

Description: The command FB is used to select quick-start mode.

Parameter description: 0: Quick-start mode switched off

1: Quick-start mode switched on

Value range: 0...1

Initial value: 1

7.3.4 Command ID

<id>ID<parameter><CR>	Identification number
Access:	Read / write
Description:	This command sets the identification number (THIES interpreter) or the slave address (MODBUS RTU interpreter). A response telegram is only transmitted if the 'id' in the command matches the one selected in the weather station. An exception here is the generic 'id', resulting in a response with all weather stations (THIES interpreter). Once the 'id' has been changed, the device immediately responds with the new 'id'.
Parameter description:	99 Generic 'id' (THIES interpreter) 0 Broadcast slave address (MODBUS RTU interpreter)
Value range:	0 to 99 (THIES interpreter) 1 to 247 (MODBUS RTU interpreter)
Initial value:	0 (THIES interpreter) 1 (MODBUS RTU interpreter)

7.3.5 Command KY

<id>KY<parameter><CR>	Key/password
Access:	Read / write
Description:	The command KY is used to select the value for the key (password). To change parameters the necessary password must be set.
Parameter description:	0 no password 234 password for user level
Value range:	0 / 234
Initial value:	0

7.3.6 Command SA

<id>SA<CR>	Scaling for the minimum value of the analog output
Access:	Read / write
Description:	The command SA can be used to set the global radiation for the minimum analog output value.
Parameter description:	Global radiation value in [W/m ²] without decimal places
Value range:	0...1500
Initial value:	0

7.3.7 Command SB

<id>SB<CR>	Scaling for the maximum value of the analog output
Access:	Read / write
Description:	The command SB can be used to set the global radiation for the maximum analog output value.
Parameter description:	Global radiation value in [W/m ²] without decimal places
Value range:	0...1800
Initial value:	1300

7.3.8 Command SV

<id>SV<CR>	Software version
Access:	Read
Description:	The command SV can be used to read the software version number, consisting of the major and minor version. The major and minor version each comprise 2 decimal positions, with the major version appearing in the two most significant positions. e.g. !00SV0102 (←corresponds to Version V01.02)
Parameter description:	-
Response telegram:	-
Value range:	-
Initial value:	-

7.3.9 Command TR

<id>TR<parameter><CR>	Telegram output
Access:	Read / write
Description:	This command initiates one-off transmission of a data telegram.
Parameter description:	1 measured value telegram
Response telegram:	See measured value telegram
Value range:	1
Initial value:	-

8 Technical data

Global radiation		
	Spectral range	380...1100nm
	Max. spectral sensitivity	780nm
	Sensor type	Silicon photodiode
	Diffuser	PTFE
	Dome	Plastic (PMMA)
	Cosine correction	Error f2 <±6%
	Linearity	<±1%
	Absolute error	<±10%
Analog output		
	Measuring range	0...1300W/m ²
7.1415.09.x51	Voltage	0...5V
7.1415.09.x61	Voltage	0...10V @ U _B > 12V
7.1415.09.x40	Current	0...20mA R _L /burden: ≤350Ω @ U _B > 12V ≤500Ω @ U _B > 15V
7:1415:09.x41	Current	4...20mA R _L /burden: ≤350Ω @ U _B > 12V ≤500Ω @ U _B > 15V
7:1415:09:041	Current	4...20mA, 2-wire circuit
Digital output		
Interface	Type	RS485
	Mode	Half duplex mode
	Baud rate	1200, 2400, 4800, 9600 , 19200, 38400, 57600
7.1415.09.2xx	Data format	-ASCII (command interpreter: THIES)
7.1415.09.3xx	Data format	-Binary (command interpreter: MODBUS RTU)
Global radiation	Measuring range	0...2000W/m ²
Inside temperature of housing	Type	Silicon sensor
	Measuring range	-30 ... +60°C
	Resolution	0,1°C
	Accuracy	± 2°C
General		
Supply	Operating voltage	9...28VDC
	Current consumption	20mA @ 12VDC
Ambient conditions	Temperature range	-30... +60°C
	Humidity range	non-condensing
	Storage temperature	-40...+80°C
Housing	Material	Aluminium, PMMA
	Dimensions	See dimension diagram
	Mounting	2 M4 screws in base plate
	Weight	Approx. 0.3kg
	Type of protection	IP67
	Type of connection	5m cable with plug

7.1415.09.xxx

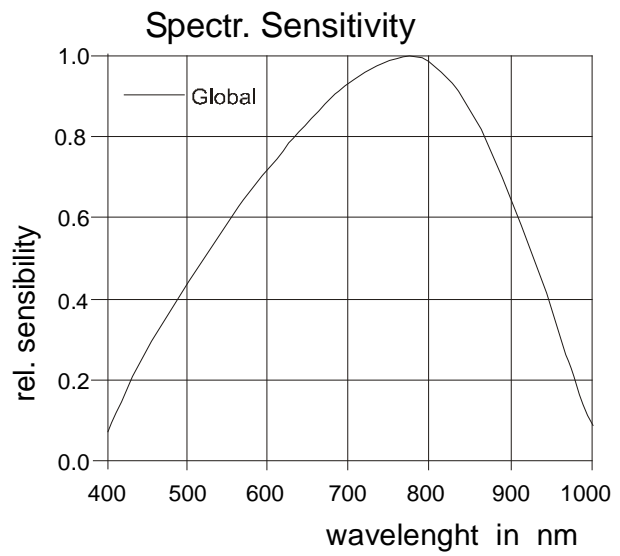

9 Dimension diagram

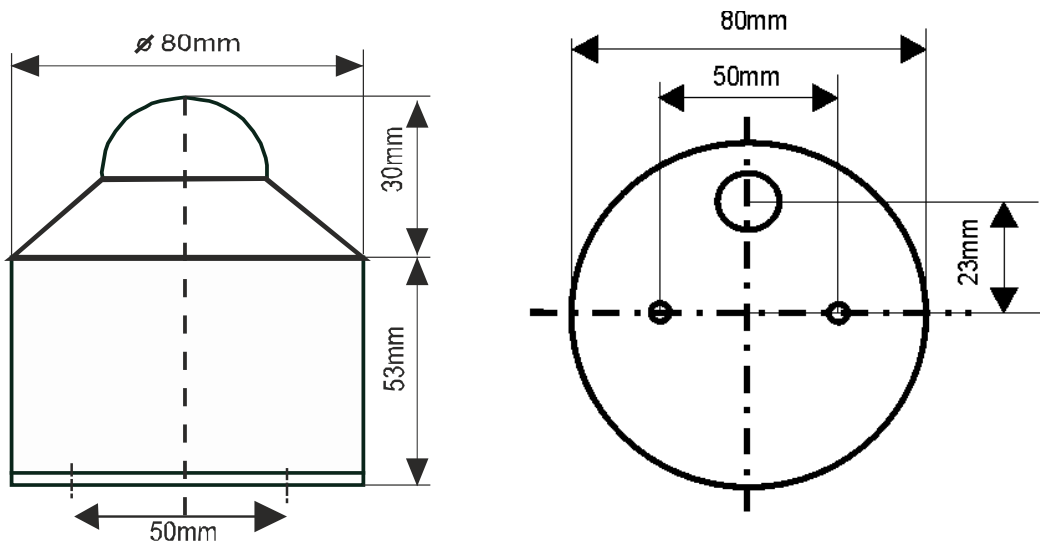

10 EC Declaration of Conformity

Document-No.: 000319

Month: 10 Year: 14

Manufacturer: **ADOLF THIES GmbH & Co. KG**

Hauptstr. 76
D-37083 Göttingen
Tel.: (0551) 79001-0
Fax: (0551) 79001-65
email: Info@ThiesClima.com

Description of Product: **Pyranometer; Silicon Pyranometer; UVAB Sensor; UVB Sensor; Silicon-Sensor PAR; Sunshine Indicator; Pyranometer with MOBBus**

Article No.	7.1415.05.040	7.1415.05.041	7.1415.05.051	7.1415.05.061
7.1415.05.240	7.1415.05.241	7.1415.05.251	7.1415.05.261	7.1415.05.340
7.1415.05.341	7.1415.05.351	7.1415.05.361	7.1415.09.040	7.1415.09.041
7.1415.09.051	7.1415.09.061	7.1415.09.240	7.1415.09.241	7.1415.09.251
7.1415.09.261	7.1415.09.340	7.1415.09.341	7.1415.09.351	7.1415.09.361
7.1415.30.051	7.1416.10.040	7.1416.10.041	7.1416.10.051	7.1416.10.061
7.1416.20.040	7.1416.20.041	7.1416.20.051	7.1416.20.061	7.1418.00.040
7.1418.00.041	7.1418.00.051	7.1418.00.061	7.1420.00.000	

specified technical data in the document: **021430/12/04; 021006/07/01; 021052/11/03; 021054/05/02; 021051/01/06 021049/05/04; 021729/09/14; 021769/09/14;**

The indicated products correspond to the essential requirement of the following European Directives and Regulations:

2004/108/EC	DIRECTIVE 2004/108/EC OF THE EUROPEAN PARLIAMENT AND OF THE COUNCIL of 15 December 2004 on the approximation of the laws of the Member States relating to electromagnetic compatibility and repealing Directive 89/336/EEC
2006/95/EC	DIRECTIVE 2006/95/EC OF THE EUROPEAN PARLIAMENT AND OF THE COUNCIL of 12 December 2006 on the harmonisation of the laws of Member States relating to electrical equipment designed for use within certain voltage limits
552/2004/EC	Regulation (EC) No 552/2004 of the European Parliament and the Council of 10 March 2004 on the interoperability of the European Air Traffic Management network (the interoperability Regulation)
2011/65/EU	DIRECTIVE 2011/65/EU OF THE EUROPEAN PARLIAMENT AND OF THE COUNCIL of 8 June 2011 on the restriction of the use of certain hazardous substances in electrical and electronic equipment

The indicated products comply with the regulations of the directives. This is proved by the compliance with the following standards:

Reference number	Specification
IEC 61000-6-1: 2005	Electromagnetic compatibility Immunity for residential, commercial and light industrial environments
IEC 61000-6-2: 2005	Electromagnetic compatibility Immunity for industrial environment
IEC 61000-6-3: 2006	Electromagnetic compatibility Emission standard for residential, commercial and light industrial environments
IEC 61010-1: 2010	Safety requirements for electrical equipment for measurement, control and laboratory use. Part 1: General requirements

Place: Göttingen

Date: 20.10.2014

Legally binding signature:

issuer:

.....
Wolfgang Behrens, General Manager

.....
Joachim Beinhorn, Development Manager

This declaration certifies the compliance with the mentioned directives, however does not include any warranty of characteristics. Please pay attention to the security advises of the provided instructions for use.

11 Accessories (optional)

Device Utility Tool	Article No. 9.1700.81.000	Free tool for selection of parameters and / or special configurations. Please send a short e-mail to info@thiesclima.com quoting "Utility Tool Pyranometer" as the reference and including your name and address and our order number or invoice number. We will then send you a login for download.
---------------------	---------------------------	---



ADOLF THIES GmbH & Co. KG

Hauptstraße 76 37083 Göttingen Germany
P.O. Box 3536 + 3541 37025 Göttingen
Phone +49 551 79001-0 Fax +49 551 79001-65
www.thiesclima.com info@thiesclima.com



- Alterations reserved-